

DIMENSIONI D'INGOMBRO - OVERALL DIMENSIONS

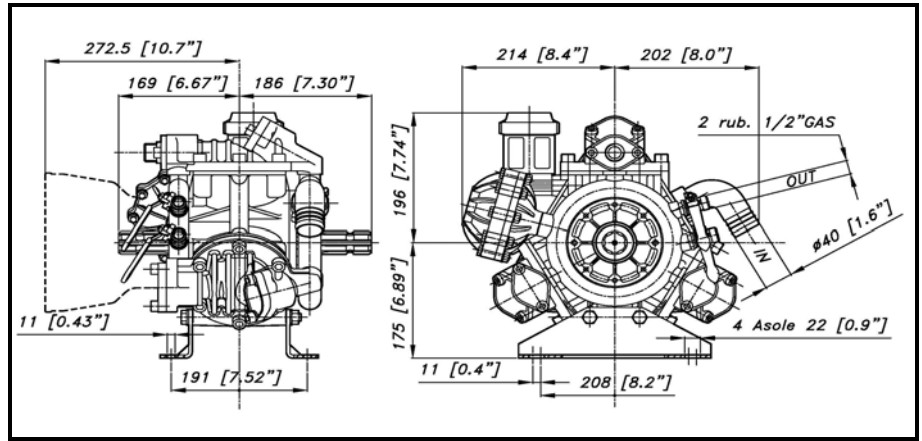

ALBERO POMPA - PUMP SHAFT

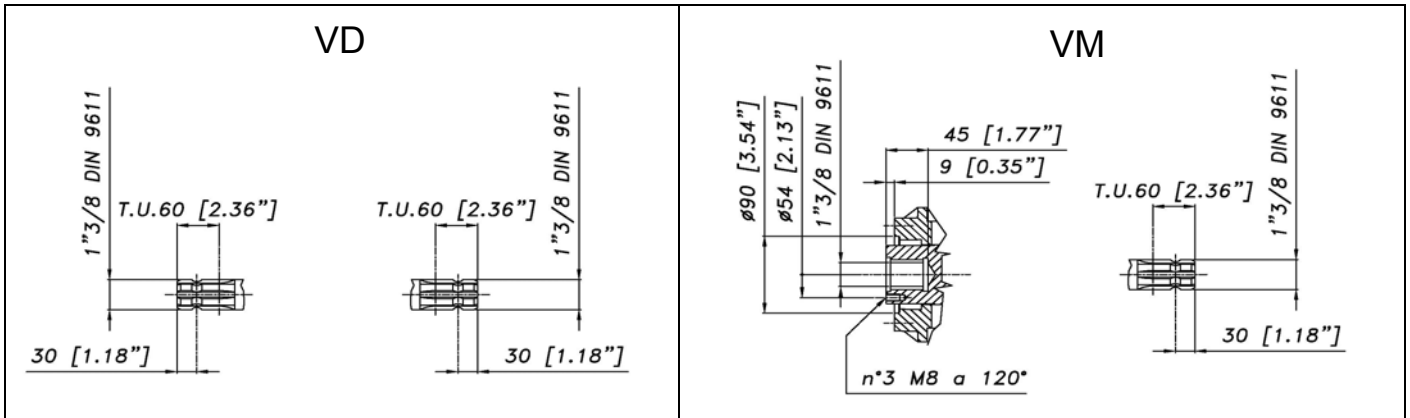

COPPIA DI SERRAGGIO - TORQUE CHART					
CODICE - CODE	Q.TY	POS	N-m	Lbr.ft	
41.9835.97.3	3	10	12	8,9	
81.4706.00.2	4	68	68	50	
86.2852.00.2	2	51	22	16,3	
86.3265.00.2	12	9	44	32,5	
86.2562.00.2	8	37	22	16,3	
86.2547.00.2	2	39	10	7,4	
86.2785.00.2	10	61	22	16,3	
86.3740.00.2	4	69	68	50	
86.4139.00.2	2	44	68	50	
86.3947.00.2	16	8	98	72,3	
86.3983.00.2	2	67	98	72,3	
Tolleranza di serraggio: 0/-10%					
Tolerance on torque value:					

INFORMAZIONI UTILI USEFUL INFORMATION				
LUBRIFICANTE- LUBRICANT:				
OLIO MOTORE O SEMIIDRAULICO SAE 30 MOTOR OIL OR SEMI-HYDRAULIC OIL SAE 30				
PRESSIONE ACCUMULATORE ACCUMULATOR PRESSURE				
PRESSIONE DI LAVORO - OPERATING PRESSURE	2 + 5	5 + 10	10 + 20	20 + 50
ACCUMULATORE ACCUMULATOR	2	2 + 5	5 + 7	6 + 8

KIT MEMBRANE - DIAPHRAGMS KIT

KIT	BUNA - N				DESMOPAN			VITON						PENTAX					
POSIZIONE ESPLOSO POSITION NUMBER	1	29	53	59	1	29	53	1	29	53	30	3	6	65	59	1	29	53	59
QUANTITA' NEL KIT QUANTITIES INCLUDED	3	3	3	1	3	3	3	3	3	3	1	6	6	1	1	3	3	3	1

KIT POMPA/KIT VALVOLE - PUMP KIT/VALVES KIT

KIT	KIT POMPA VD - VM PUMP KIT VD - VM								KIT VALVOLE VALVES KIT		
POSIZIONE ESPLOSO POSITION NUMBER	3	6	18	26	29	35	38	53	2	3	6
QUANTITA' NEL KIT QUANTITIES INCLUDED	6	6	1	1	3	1	1	3	6	6	6

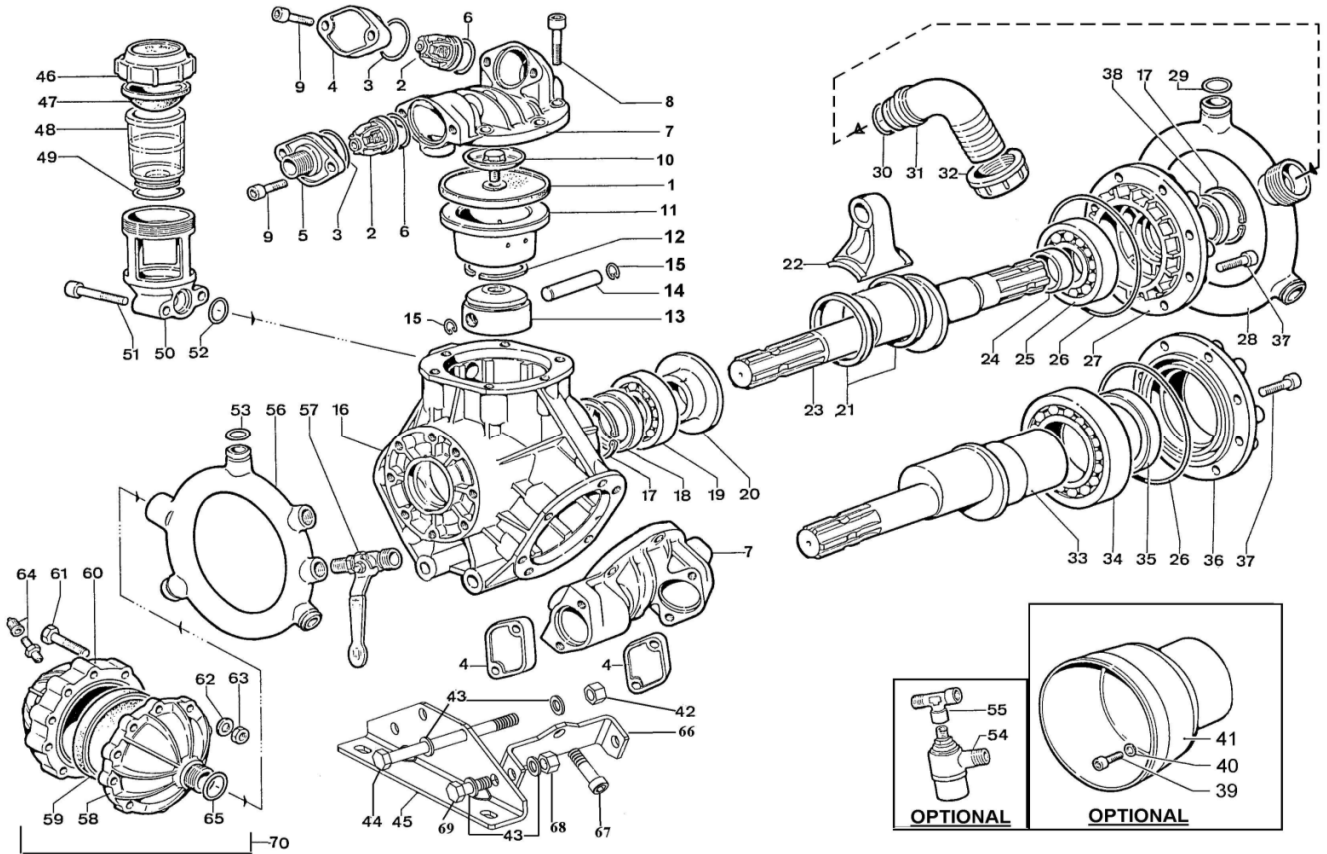

POS.	CODICE PART NO. REF.	DENOMINAZIONE - DESCRIPTION - DESCRIPTION	Q.TY	POS.	CODICE PART NO. REF.	DENOMINAZIONE - DESCRIPTION - DESCRIPTION	Q.TY
1	95.0040.31.2	PISTON DIAPHRAGM (OPT.)	3	33	48.0009.26.2	CRANKSHAFT "VM" (1"3/8 M-F)	1
1	95.0040.33.2	VITON PISTON DIAPHRAGM (OPT.)	3	34	81.3020.00.2	BEARING 70X125X24	1
1	95.0040.00.2	DESMOPAN PISTON DIAPHRAGM (OPT.)	3	35	80.2264.10.2	OIL SEAL DIA.68x90x10	1
1	95.0040.36.2	HPS PISTON DIAPHRAGM (OPT.)	3	36	48.0004.09.2	BALL BEARING COVER "VM" (before 06/2017)	1
2	35.9802.97.3	VALVE ASSY	6	36	48.0035.09.2	BALL BEARING COVER "VM" (after 06/2017)	1
3	80.3262.00.2	O-RING 3,53x41,28	6	37	86.2562.00.2	SCREW M8x20 UNI5931 (before 06/2017)	8
3	80.3262.50.2	O-RING 3,53x41,28 (KIT VITON)	6	37	86.3216.00.2	SCREW M10x20 DIN 7984 (after 06/2017)	8
4	35.0008.28.2	BRASS VALVE COVER	5	38	80.2178.10.2	OIL SEAL DIA.40x52x7	1
5	35.0018.28.2	VALVE COVER	1	39	86.2547.00.2	SCREW M8x18	2
6	80.3251.00.2	O-RING 3,53x32,93	6	40	84.3696.00.2	WASHER DIA.8,4x18x2 (OPT.)	2
6	80.3251.50.2	O-RING 3,53x32,93 (KIT VITON)	6	41	31.1468.32.2	PLAIN SAFETY CONE (OPTIONAL)	1
7	48.0027.28.2	HEAD	3	41	31.1482.32.2	PLAIN SAFETY CONE (OPTIONAL)	1
8	86.3947.00.2	SCREW M12X40 12.9 UNI 5931	16	42	81.4706.00.2	GALVANIZED HEXAGON NUT M12X6	6
9	86.3265.00.2	SCREW M10x25 UNI5931	12	44	86.4139.00.2	SCREW M12x160	2
10	41.9835.97.3	S.S. DISK + DIAPHRAGM LOCKING BOLT	3	45	48.0031.61.2	MOUNTING RAIL	2
11	48.0029.01.2	PISTON SLEEVE DIA.70	3	46	28.0144.32.2	OIL FILLER CAP	1
12	81.8530.00.2	PISTON RING DIA.70	6	47	41.0017.31.2	OIL FILLER DIAPHRAGM	1
13	48.0028.09.2	PISTON DIA.70	3	48	41.0016.32.2	OIL FILLER	1
14	85.2007.00.2	PISTON PIN DIA.15x54	3	49	80.3209.40.2	O-RING 2,62x44,12	1
15	80.0021.00.2	RING DIA.15	6	50	35.0009.09.0	BOWL OIL FILLER	1
16	48.0001.08.2	CRANKCASE (before 06/2017)	1	51	86.2852.00.2	SCREW M8x45 UNI5931	2
16	48.0036.08.2	CRANKCASE (after 06/2017)	1	52	80.3195.00.2	O-RING 2,62x20,24	1
17	80.1369.00.2	RING DIA.52	2	53	80.3189.00.2	O-RING 2,62x18,72	3
18	80.2143.10.2	OIL SEAL DIA.35x52x7	1	53	80.3189.50.2	O-RING 2,62x18,72 (KIT VITON)	3
19	81.2867.00.2	BEARING DIA.35x80x21	1	54	24.3050.97.3	SAFETY VALVE 50bar (OPTIONAL)	1
20	48.0007.01.2	SPACER	1	55	83.5020.00.2	3/8 FEMALE-MALE TEE (OPT.)	1
21	14.0015.76.2	CONROD RING	2	56	48.0026.12.2	INLET MANIFOLD	1
22	41.0047.11.2	CONROD	3	57	84.5544.00.2	RIGHT TAP G.3/8-G.1/2	2
23	41.0033.26.2	CRANKSHAFT "VD" VERSION (1"3/8 M-M)	1	58	48.0021.28.2	LOWER BALLASTER	1
24	48.0008.41.2	SPACER "VD"	1	59	93.0041.31.2	BALLASTER DIAPHRAGM	1
25	81.2913.00.2	BEARING DIA.40x90x23	1	60	93.0003.09.2	TOP BALLASTER	1
26	80.3210.68.2	O-RING 2,62x120,32	1	60	48.0033.28.2	TOP BALLASTER (BR. VERSION) (OPT.)	1
27	48.0003.09.2	BEARING COVER (before 06/2017)	1	61	86.2785.00.2	SCREW M 8X40	10
27	48.0034.09.2	BEARING COVER (after 06/2017)	1	61	86.2694.00.2	SCREW M8X30 UNI5737 (BR. VERSION) (OPT.)	10
28	48.0025.12.2	INLET MANIFOLD	1	62	84.3685.00.2	WASHER DIA.8,4x15x1,5	10
29	80.3204.00.2	O-RING 2,62x23,81	3	63	81.4575.00.2	NUT M8 UNI5588	10
29	80.3204.00.2	O-RING 2,62x23,81	3	64	86.1605.00.2	AIR VALVE	1
30	80.3219.10.2	ANELLO OR 3,0x30 (OPTIONAL)	1	65	80.3200.00.2	O-RING 2,62x22,22	1
30	80.3255.00.2	O-RING 3,53x36,1	1	65	80.3200.50.2	O-RING 2,62x22,22 (KIT VITON)	1
30	80.3255.50.2	O-RING 3,53x36,1 (KIT VITON)	1	66	48.0030.68.2	BRACKET	2
31	84.0591.00.2	90 E.C. DIA.40-1,57" (PLAST. OPT.)	1	67	86.3983.00.2	SCREW TCEI M12X45	2
31	84.0593.00.2	90 ELBOW CONNECTOR D.40-1,57"	1	69	86.3703.00.2	SCREW TE M12x25 UNI 5739	4
32	82.0070.00.2	WING NUT G.1"1/2 (OPT.)	1	70	48.9802.97.3	BALLASTER COVER (AL. VERSION) (OPT.)	1
32	82.0071.00.2	WING NUT G.1"1/2	1	70	48.9817.97.3	BALLASTER COVER (BR. VERSION) (OPT.)	1