

DIMENSIONI D'INGOMBRO - OVERALL DIMENSIONS

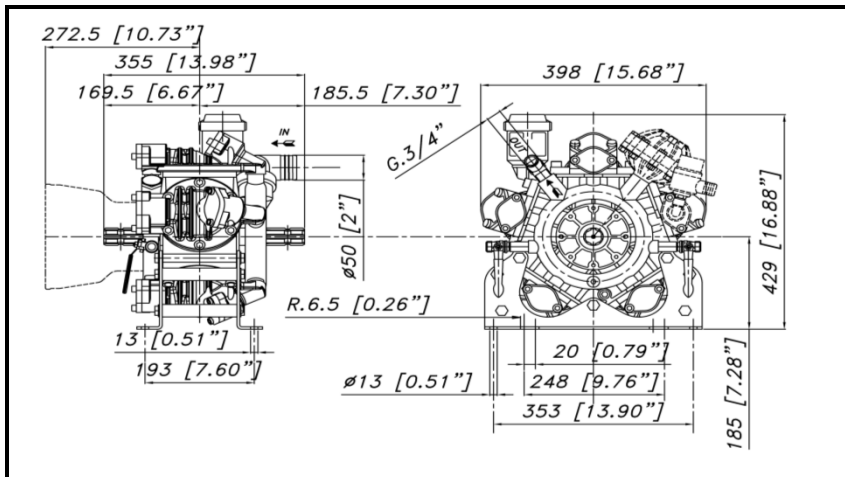

ALBERO POMPA - PUMP SHAFT

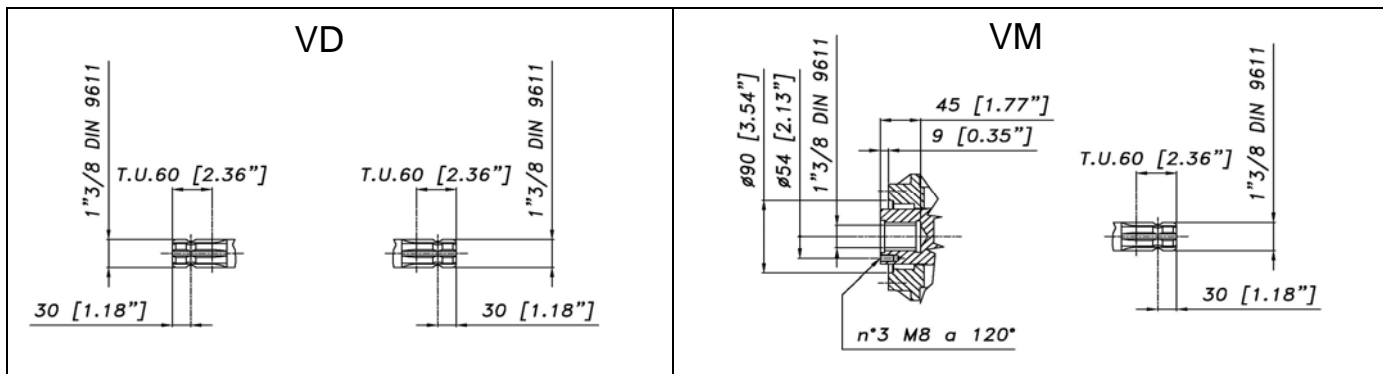

COPPIA DI SERRAGGIO - TORQUE CHART					
CODICE - CODE	Q.TY	POS	N-m	Lbr.ft	
49.9800.97.3	5	10	25	18,5	
81.4706.00.2	3	54	68	50	
86.2562.00.2	2	53	22	16,3	
86.3216.00.2	8	36	44	32,5	
86.3265.00.2	20	6	44	32,5	
86.3694.50.2	1	82	40	29,5	
86.3947.00.2	30	8	98	72,3	
86.4139.00.2	3	48	68	50	

Tolleranza di serraggio: 0/-10%
Tolerance on torque value: 0/-10%

INFORMAZIONI UTILI USEFUL INFORMATION				
LUBRIFICANTE - LUBRICANT: OLIO MOTORE O SEMIIDRAULICO SAE 30 MOTOR OIL OR SEMI-HYDRAULIC OIL SAE 30				
PRESSIONE ACCUMULATORE ACCUMULATOR PRESSURE				
PRESSIONE DI LAVORO - OPERATING PRESSURE	2 ÷ 5	5 ÷ 10	10 ÷ 20	20 ÷ 50
ACCUMULATORE ACCUMULATOR	2	2 ÷ 5	5 ÷ 7	6 ÷ 8

KIT MEMBRANE - DIAPHRAGMS KIT

KIT	BUNA - N			DESMOPAN			VITON					PENTAX			
	49.9808.97.3			49.9809.97.3			49.9810.97.3								
POSIZIONE ESPLOSO POSITION NUMBER	1	50	52	1	50	52	1	50	52	5	3	31	1	50	52
QUANTITA' NEL KIT QUANTITIES INCLUDED	5	5	5	5	5	5	5	7	5	10	10	1	5	5	5

KIT POMPA/KIT VALVOLE - PUMP KIT/VALVES KIT

KIT	KIT POMPA VD PUMP KIT VD							KIT VALVOLE VALVES KIT						
	49.9805.97.3							49.9806.97.3						
POSIZIONE ESPLOSO POSITION NUMBER	3	5	18	27	35	50	52	2	3	5				
QUANTITA' NEL KIT QUANTITIES INCLUDED	10	10	1	1	1	7	5	10	10	10				

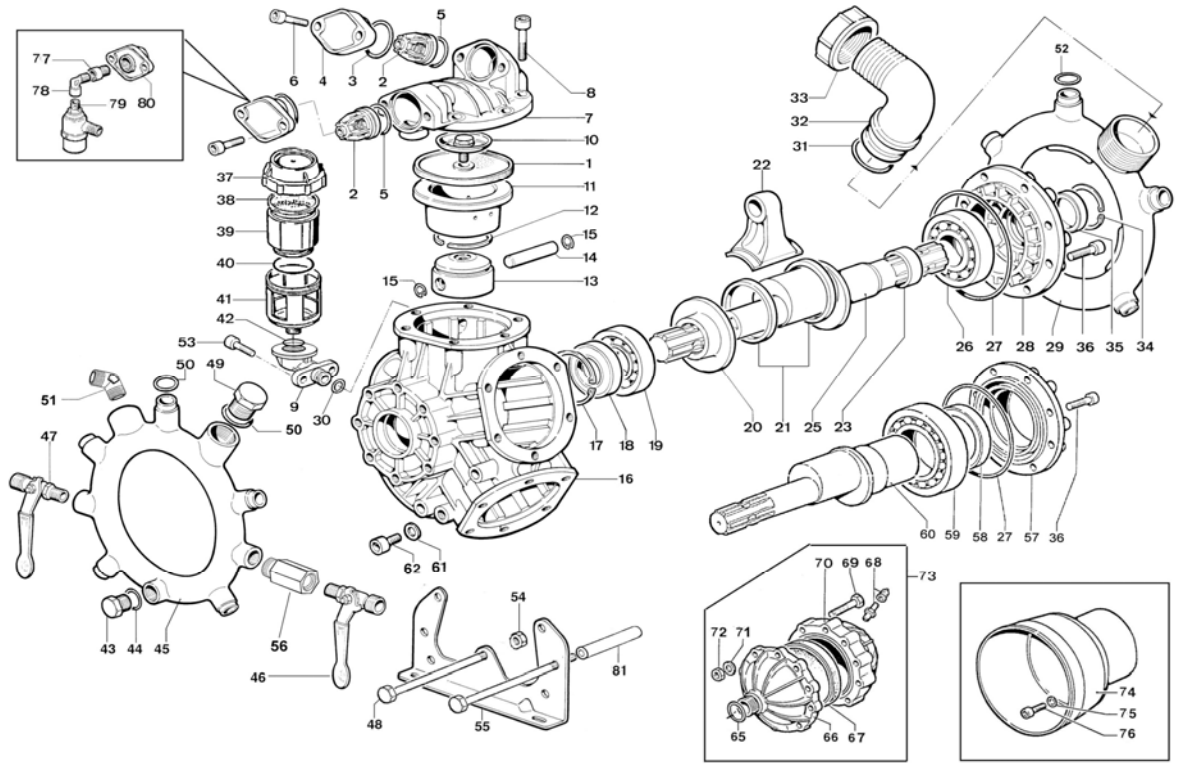

POS.	CODICE PART NO. REF.	DENOMINAZIONE - DESCRIPTION - DESCRIPTION	Q.TY	POS.	CODICE PART NO. REF.	DENOMINAZIONE - DESCRIPTION - DESCRIPTION	Q.TY
1	95.0040.31.2	PISTON DIAPHRAGM	5	40	80.3209.40.2	O-RING 2.62x44,12	1
1	95.0040.33.2	PISTON DIAPHRAGM VITON (OPT.)	5	41	41.0015.09.0	BOWL OIL FILLER	1
1	95.0040.00.2	PISTON DIAPHRAGM DESMOPAN (OPT.)	5	42	80.3205.50.2	O-RING 2,62x26,65	1
1	95.0040.36.2	PISTON DIAPHRAGM HPS (OPT.)	5	43	85.2579.00.2	CAP G.3/8	1
2	35.9802.97.3	VALVE ASSY	10	44	82.4109.00.2	GASKET DIA.17X22X1	1
3	80.3262.00.2	O-RING 3,53x41,28	10	45	49.0004.12.2	OUTLET MANIFOLD	1
3	80.3262.50.2	O-RING 3,53x41,28 (KIT VITON)	10	46	84.5544.00.2	RIGHT TAP G.3/8-G.1/2	1
4	35.0008.28.2	BRASS VALVE COVER	10	47	84.5544.10.2	LEFT TAP G.3/8-G.1/2	1
5	80.3251.00.2	O-RING 3,53x32,93	10	48	86.4139.00.2	SCREW M12x160	7
5	80.3251.50.2	O-RING 3,53x32,93 (KIT VITON)	10	49	85.2693.00.2	CAP G.3/4	1
6	86.3265.00.2	SCREW M10x25	20	50	80.3189.00.2	O-RING 2.62x18.72	6
7	48.0027.28.2	PUMP HEAD	5	50	80.3189.50.2	O-RING 2.62x18.72 (KIT VITON)	6
8	86.3947.00.2	SCREW M12X40	30	51	83.5063.28.2	CONNECTOR 60° G 3/4 M-M	1
9	49.0019.08.2	OIL FILLER COUPLING	1	52	80.3204.00.2	O-RING 2,62x23,81	5
10	49.9800.97.3	DISK-DIAPHRAGM LOCKING BOLT KIT	5	52	80.3204.50.2	O-RING 2,62x23,81 (KIT VITON)	5
11	49.0008.01.2	PISTON SLEEVE	5	53	86.2562.00.2	SCREW M8x20	2
12	81.8514.00.2	PISTON RING DIA.62x2,5	10	54	81.4706.00.2	NUT M12	7
13	49.0007.09.2	PISTON	5	55	49.0028.61.2	MOUNTING RAIL	2
14	85.2007.00.2	PISTON PIN	5	56	49.0021.53.2	EXTENSION	2
15	80.0021.00.2	RING DIA.15	10	57	48.0004.09.2	BEARING COVER VM (before 11/2017)	1
16	49.0023.09.2	CRANKCASE (before 11/2017)	1	57	48.0035.09.2	BEARING COVER VM (after 11/2017)	1
16	49.0030.09.2	CRANKCASE (after 11/2017)	1	58	80.2264.10.2	OIL SEAL DIA.68x90x10	1
17	80.1369.00.2	RING DIA.52	1	59	81.3020.00.2	BEARING 70X125X24	1
18	80.2143.10.2	OIL SEAL DIA.3	1	60	48.0009.26.2	CRANKSHAFT "VM" (1"3/8 M-F)	1
19	81.2876.50.2	BEARING 35X100X25	1	61	82.4066.00.2	GASKET	1
20	49.0011.01.2	SPACER	1	62	86.3694.50.2	SCREW M12x20	1
21	14.0015.76.2	CONROD RING	2	65	80.3200.00.2	O-RING 2.62x22.2 (OPT.)	1
22	49.0012.11.2	CONROD	5	65	80.3200.00.2	O-RING 2.62x22.2 (OPT.)	1
23	48.0008.41.2	SPACER	1	66	48.0021.28.2	LOWER BALLASTER (OPT.)	1
25	41.0033.26.2	CRANKSHAFT "VD" (1"3/8 M-M)	1	67	93.0041.31.2	BALLASTER DIAPHRAGM (OPT.)	1
26	81.2914.00.2	BEARING 40X90X23	1	67	93.0041.33.2	BALLASTER DIAPHRAGM (VITON) (OPT.)	1
27	80.3210.68.2	O-RING 2,62x120,32	1	68	86.1608.50.2	AIR VALVE (OPT.)	1
28	48.0003.09.2	BEARING COVER (before 11/2017)	1	69	86.2785.00.2	SCREW M8X40 UNI5737 (AL. VERSION) (OPT.)	10
28	48.0034.09.2	BEARING COVER (after 11/2017)	1	69	86.2785.00.2	SCREW M8X30 UNI5737 (BR. VERSION) (OPT.)	10
29	49.0003.12.2	INLET MANIFOLD	1	70	93.0003.09.2	BALLASTER COVER (AL. VERSION) (OPT.)	1
30	80.3180.00.2	O-RING 2,62x15,08	1	70	48.0033.28.2	BALLASTER COVER (BR. VERSION) (OPT.)	1
31	80.3265.00.2	O-RING 3,53x46,04	1	71	84.3685.00.2	WASHER DIA.8,2X15X1,5 UNI1750 (OPT.)	10
31	80.3265.50.2	O-RING 3,53x46,04 (KIT VITON)	1	72	81.4575.00.2	NUT M8 UNI5588 (OPT.)	10
31	80.3209.10.2	O-RING 2.62x40.95 (OPT.)	1	73	48.9802.97.3	BALLASTER KIT BR./AL. (OPT.)	1
32	84.0592.00.2	90 ELBOW CONNECTOR 40-1,57"	1	73	48.9817.97.3	BALLASTER KIT BR./BR. (OPT.)	1
32	84.0590.00.2	90 ELBOW CONNECTOR. 40-1,57" PLAST.(OPT.)	1	74	31.1482.32.2	PLAIN SAFETY CONE L=180 (OPT.)	1
33	82.0121.00.2	2" WING NUT	1	74	31.1468.32.2	PLAIN SAFETY CONE L=135 (OPT.)	1
33	82.0120.00.2	2" WING NUT PLAST.(OPT.)	1	75	84.3696.00.2	WASHER DIA8,4X18X2 (OPT.)	2
34	80.1369.00.2	RING DIA.52	1	76	86.2547.00.2	SCREW TCEI M8x18 UNI5931 (OPT.)	2
35	80.2178.10.2	OIL SEAL	1	77	83.5033.00.2	REDUCTION G.1/2-G.3/8 (OPT.)	1
36	86.2562.00.2	SCREW M8x20 (before 11/2017)	10	78	82.2044.50.2	ELBOW M/F G.3/8 (OPT.)	1
36	86.3216.00.2	SCREW M10x20 (after 11/2017)	10	79	24.3050.97.3	SAFETY VALVE 50 BAR (OPT.)	1
37	28.0144.32.2	OIL FILLER CAP	1	80	35.0019.28.2	VALVE COVER G.1/2 F. (OPT.)	1
38	41.0017.31.2	OIL FILLER DIAPHRAGM	1	81	49.0029.75.2	SPACER	4
39	41.0016.32.2	OIL FILLER	1				