

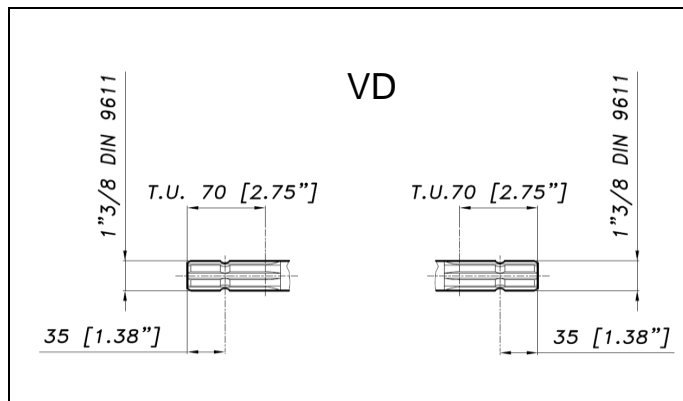

ALBERO POMPA - PUMP SHAFT

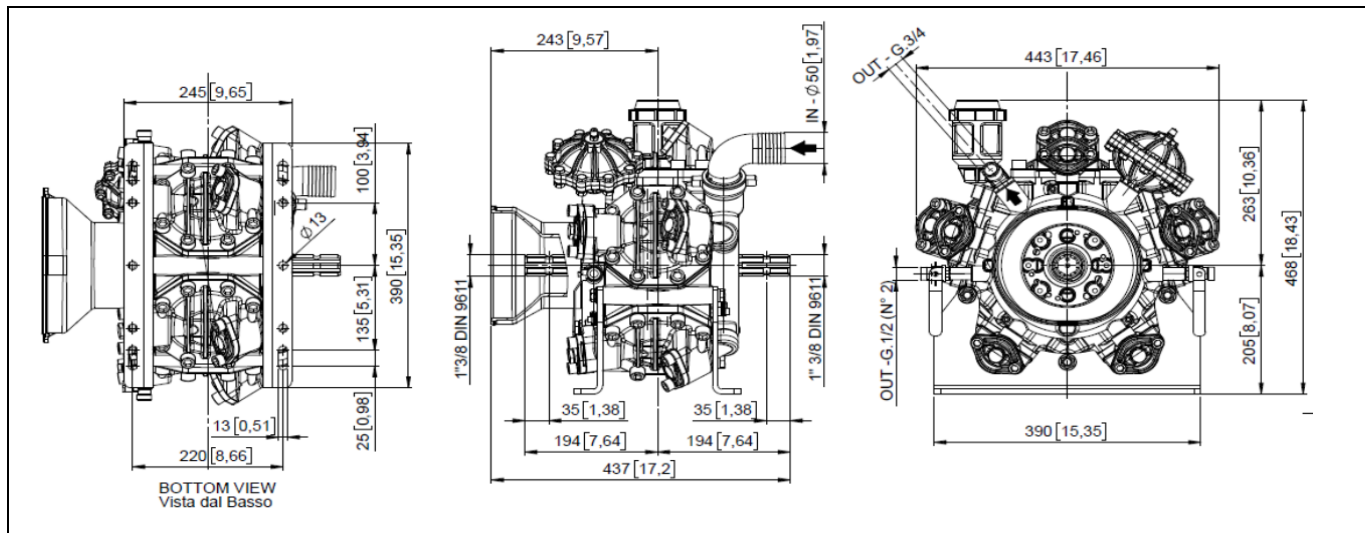

DIMENSIONI D'INGOMBRO - OVERALL DIMENSIONS



COPPIA DI SERRAGGIO - TORQUE CHART					
CODICE - CODE	Q.TY	POS	N-m	Lbr.ft	
51.9802.97.3	5	43	25	18,5	
86.3696.00.2	20	60	68	50	
86.2694.00.2	10	27	22	16,3	
81.4706.00.2	3	57	68	50	
86.4200.00.2	40	10	105	77,7	
86.3212.00.2	16	62	44	32,5	
86.2108.00.2	6	35	10	8	

Tolleranza di serraggio: 0/-10%
Tolerance on torque value: 0/-10%

INFORMAZIONI UTILI USEFUL INFORMATION				
LUBRIFICANTE- LUBRICANT: OLIO MOTORE O SEMIDRAULICO SAE 30 MOTOR OIL OR SEMI-HYDRAULIC OIL SAE 30				
PRESSIONE ACCUMULATORE ACCUMULATOR PRESSURE				
PRESSIONE DI LAVORO - OPERATING PRESSURE	2 ÷ 5	5÷10	10 ÷ 20	20 ÷ 50
ACCUMULATORE ACCUMULATOR	2	2 ÷ 5	5 ÷ 7	6 ÷ 8

KIT MEMBRANE - DIAPHRAGMS KIT

KIT	51.9803.97.3	BUNA - N			51.9804.97.3	DURAMAX			51.9805.97.3	VITON						51.9806.97.3	PENTAX		
		1	68	69		1	68	69		1	68	69	4	5	31		34	53	1
POSIZIONE ESPLOSO POSITION NUMBER																			
QUANTITA' NEL KIT QUANTITIES INCLUDED	5	5	5	5	5	5	5	5	5	5	5	5	5	5	5	5	5	5	5

KIT POMPA/KIT VALVOLE - PUMP KIT/VALVES KIT

KIT	51.9807.97.3	KIT POMPA VD PUMP KIT VD					51.9808.97.3	KIT VALVOLE VALVES KIT		
		68	69	64	67	34		2	4	5
POSIZIONE ESPLOSO POSITION NUMBER										
QUANTITA' NEL KIT QUANTITIES INCLUDED	10	10	2	2	1	10	10	10		

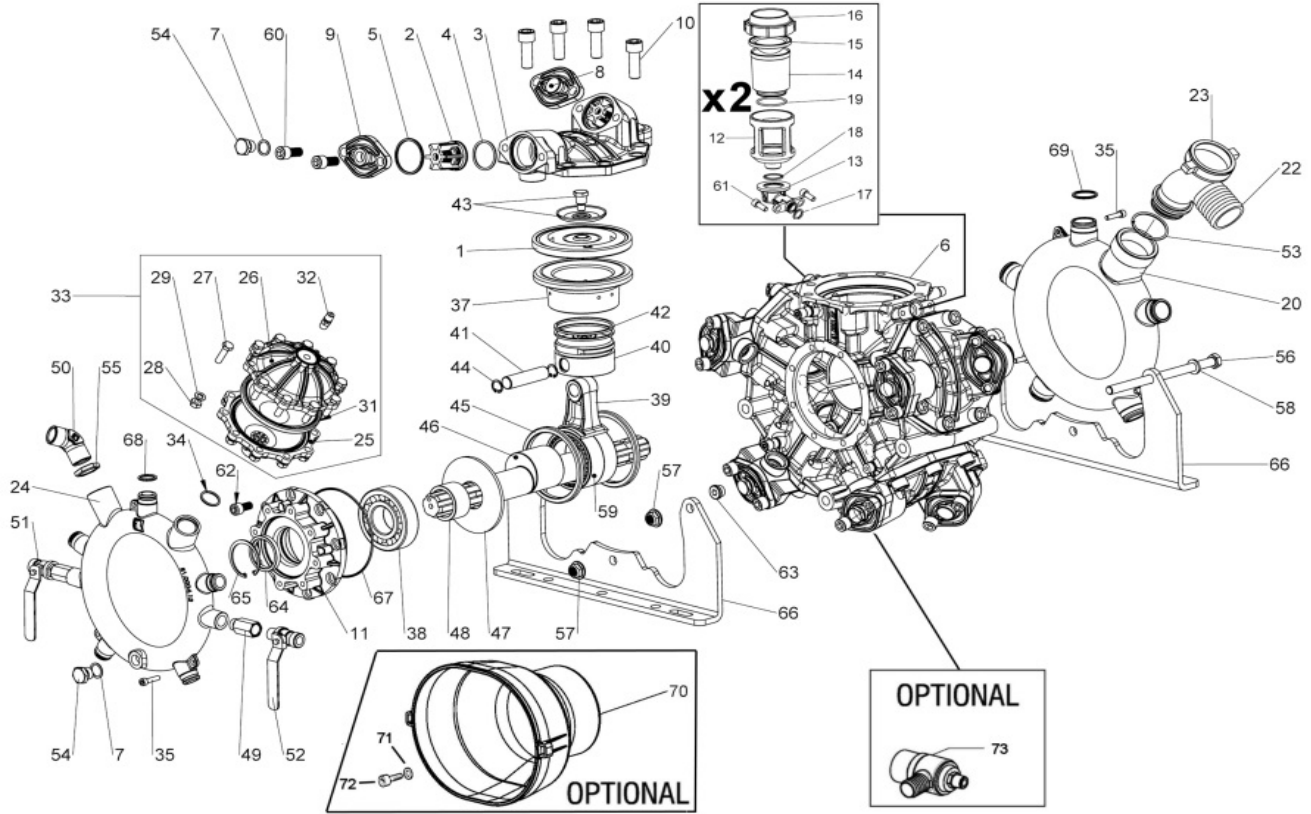

POS.	CODICE PART NO. REF.	DENOMINAZIONE - DESCRIPTION - DESCRIPTION	Q.TY
1	51.0040.31.2	PISTON DIAPHRAGM	5
1	51.0040.33.2	PISTON DIAPHRAGM VITON (OPT.)	5
1	51.0040.00.ADS	PISTON DIAPHRAGM DURAMAX (OPT.)	5
1	51.0040.37.2	PISTON DIAPHRAGM PENTAX (OPT.)	5
2	51.9801.97.3	VALVE ASSY	10
3	51.0002.28.2	PUMP HEAD	5
4	80.3253.00.2	O-RING 3,53X34,52	10
4	80.3254.00.2	O-RING 3,53X34,52 (KIT VITON)	10
5	80.3264.00.2	O-RING 3,53X44,04	10
5	80.3264.50.2	O-RING 3,53X44,04 (KIT VITON)	10
6	51.0001.07.2	CRANKCASE	1
7	82.4109.00.2	GASKET DIA.17x22x1 COPPER	6
8	51.0005.28.2	VALVE COVER	5
9	51.0006.28.2	VALVE COVER G.3/8 F.	5
10	86.4200.00.2	SCREW M14X40	40
11	48.0034.09.2	BEARING COVER	2
12	41.0015.09.0	BOWL OIL FILLER	2
13	51.0021.08.2	OIL FILLER COUPLING	2
14	41.0016.32.2	OIL FILLER	2
15	41.0017.31.2	OIL FILLER DIAPHRAGM	2
16	28.0144.32.2	OIL FILLER CAP	2
17	80.3180.00.2	O-RING 2.62x15.08	2
18	80.3205.50.2	O-RING 2,62x26,65	2
19	80.3209.40.2	O-RING 2,62x44,12	2
20	51.0003.12.2	INLET MANIFOLD	1
22	84.0611.00.2	90 ELBOW CONNECTOR 50-1,96"	1
22	84.0610.00.2	90 ELBOW CONNECTOR 50-1,96" PLAST.(OPT.)	1
23	82.0121.00.2	G.2" WING NUT	1
23	82.0120.00.2	G.2" WING NUT PLAST.(OPT.)	1
24	51.0004.12.2	OUTLET MANIFOLD	1
25	48.0021.28.2	LOWER BALLASTER	1
26	48.0033.28.2	BALLASTER COVER	1
27	86.2694.00.2	SCREW M8X30	10
28	81.4575.00.2	NUT M8	10
29	84.3685.00.2	WASHER DIA.8,2X15X1,5	10
31	93.0041.31.2	BALLASTER DIAPHRAGM	1
31	93.0041.33.2	BALLASTER DIAPHRAGM (VITON)	1
32	86.1608.50.2	AIR VALVE	1
33	48.9817.97.3	BALLASTER KIT BR./BR.	1
34	80.3200.00.2	O-RING 2.62x22.2	1
34	80.3200.50.2	O-RING 2.62x22.2 (KIT VITON)	1
35	86.2108.00.2	SCREW M6X16 UNI5931	6

POS.	CODICE PART NO. REF.	DENOMINAZIONE - DESCRIPTION - DESCRIPTION	Q.TY
37	51.0010.0.12	PISTON SLEEVE	5
38	81.2909.00.2	ROLLER BEARING (21308)	2
39	51.0008.11.2	CONROD	5
40	51.0009.09.2	PISTON	5
41	85.2027.00.2	PISTON PIN	5
42	81.8540.00.2	PISTON RING	10
43	51.9802.97.3	DISK-DIAPHRAGM LOCKING BOLT KIT	5
44	80.0038.00.2	RING DIA.18	10
45	51.0016.41.2	CONROD RING	2
46	51.0011.26.2	CRANKSHAFT VD (1" 3/8 M-M)	1
47	51.0017.61.2	SPACER	2
48	51.0018.48.2	SPACER	2
49	49.0021.53.2	EXTENSION	2
50	83.5063.28.0	CONNECTOR 60° G 3/4" M-M	1
51	84.5544.10.2	LEFT TAP G.3/8-G.1/2	1
52	84.5544.00.2	RIGHT TAP G.3/8-G.1/2	1
53	80.3265.00.2	O-RING 3,53x46,04	1
53	80.3265.50.2	O-RING 3,53x46,04 (KIT VITON)	1
54	85.2579.00.2	CAP G.3/8	1
55	81.4909.00.2	NUT G.3/4	6
56	86.4139.45.2	SCREW M12x190	3
57	81.4706.00.2	NUT M12	3
58	84.3844.00.2	GASKET	3
59	81.3062.00.2	BEARING (NA 4912)	2
60	86.3696.00.2	SCREW M12X25	20
61	86.2562.00.2	SCREW M8X20	4
62	86.3212.00.2	SCREW M10X20	16
63	85.2587.00.2	CAP G.3/8 + O-RING	1
64	80.2178.10.2	OIL SEAL 40X52X7	2
65	80.1369.00.2	RING DIA.52	2
66	51.0007.61.2	MOUNTING RAIL	2
67	80.3210.68.2	O-RING D.2,62X120,32	2
68	80.3189.00.2	O-RING 2,62X18,72	5
68	80.3189.50.2	O-RING 2,62x18.72 (KIT VITON)	5
69	80.3206.00.2	O-RING 2,62X28,25	5
69	80.3206.50.2	O-RING 2,62X28,25 (KIT VITON)	5
70	31.1482.32.2	PLAIN SAFETY CONE L=180 (OPT.)	1
70	31.1468.32.2	PLAIN SAFETY CONE L=135 (OPT.)	1
71	84.3696.00.2	WASHER DIA8,4X18X2 (OPT.)	2
72	86.2547.00.2	SCREW TCEI M8x18 UNI5931 (OPT.)	2
73	24.3050.97.3	SAFETY VALVE 50 BAR (OPT.)	1