

DIMENSIONI D'INGOMBRO - OVERALL DIMENSIONS

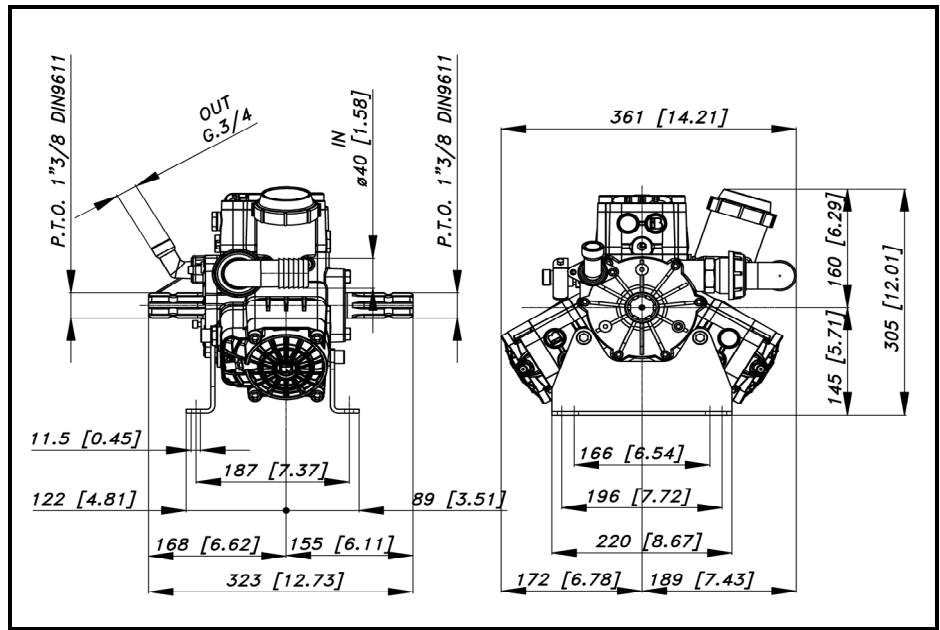

ALBERO POMPA VD - VD PUMP SHAFT

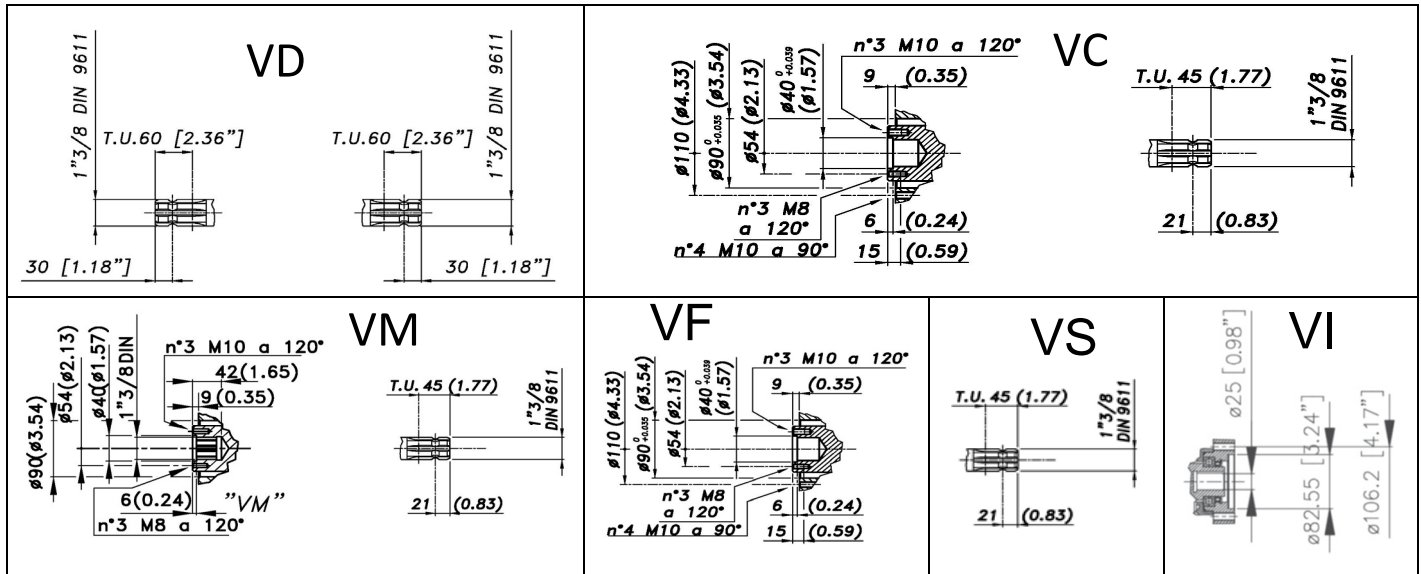

COPPIA DI SERRAGGIO - TORQUE CHART					
CODICE - CODE	Q.TY	POS	N-m	Lbr.ft	
86.3601.00.2	4	7	44	32.5	
85.2579.53.2	2	10	44	32.5	
23.0043.98.3	3	14	12	8.9	
86.2108.00.2	2	30	10	7.4	
86.3696.00.2	4	31	68	50.2	
85.2585.00.2	1	32	44	32.5	
86.2216.00.2	6	34	10	7.4	
86.3638.00.2	8	41	44	32.5	
86.3187.10.2	4	56	44	32.5	
86.2683.00.2	2	63	8	5.9	

Tolleranza di serraggio: 0/-10%
Tolerance on torque value:

INFORMAZIONI UTILI USEFUL INFORMATION				
LUBRIFICANTE - LUBRICANT: OLIO MOTORE O SEMIIDRAULICO SAE 30 MOTOR OIL OR SEMI-HYDRAULIC OIL SAE 30				
PRESSIONE ACCUMULATORE ACCUMULATOR PRESSURE				
PRESSIONE DI LAVORO - OPERATING PRESSURE	2 + 5	5 + 10	10 + 20	20 + 50
ACCUMULATORE ACCUMULATOR	2	2 + 5	5 + 7	6 + 8

KIT MEMBRANE - DIAPHRAGMS KIT

KIT	BUNA - N				DESMOPAN				VITON								PENTAX				
	1	11	12	38	1	11	12	38	1	11	12	3	5	8	24	26	38	1	11	12	38
POSIZIONE ESPLOSO POSITION NUMBER	23.9907.97.3				23.9908.97.3				23.9909.97.3								23.9910.97.3				
QUANTITA' NEL KIT QUANTITIES INCLUDED	3	4	3	2	3	3	3	2	3	4	3	6	3	3	1	1	2	3	3	3	2

KIT POMPA VD - KIT VALVOLE PUMP KIT VD - VALVES KIT

KIT	KIT POMPA VD PUMP KIT VD					KIT POMPA VC-VM PUMP KIT VC-VM					KIT VALVOLE VALVE KIT									
	54	36	11	12	3	5	8	15	76	36	11	12	3	5	8	15	2	3	5	8
POSIZIONE ESPLOSO POSITION NUMBER	23.9911.97.3					23.9915.97.3					23.9912.97.3									
QUANTITA' NEL KIT QUANTITIES INCLUDED	1	1	4	3	6	3	3	3	1	1	4	3	6	3	3	3	6	6	6	6

PA-S 830 - 930

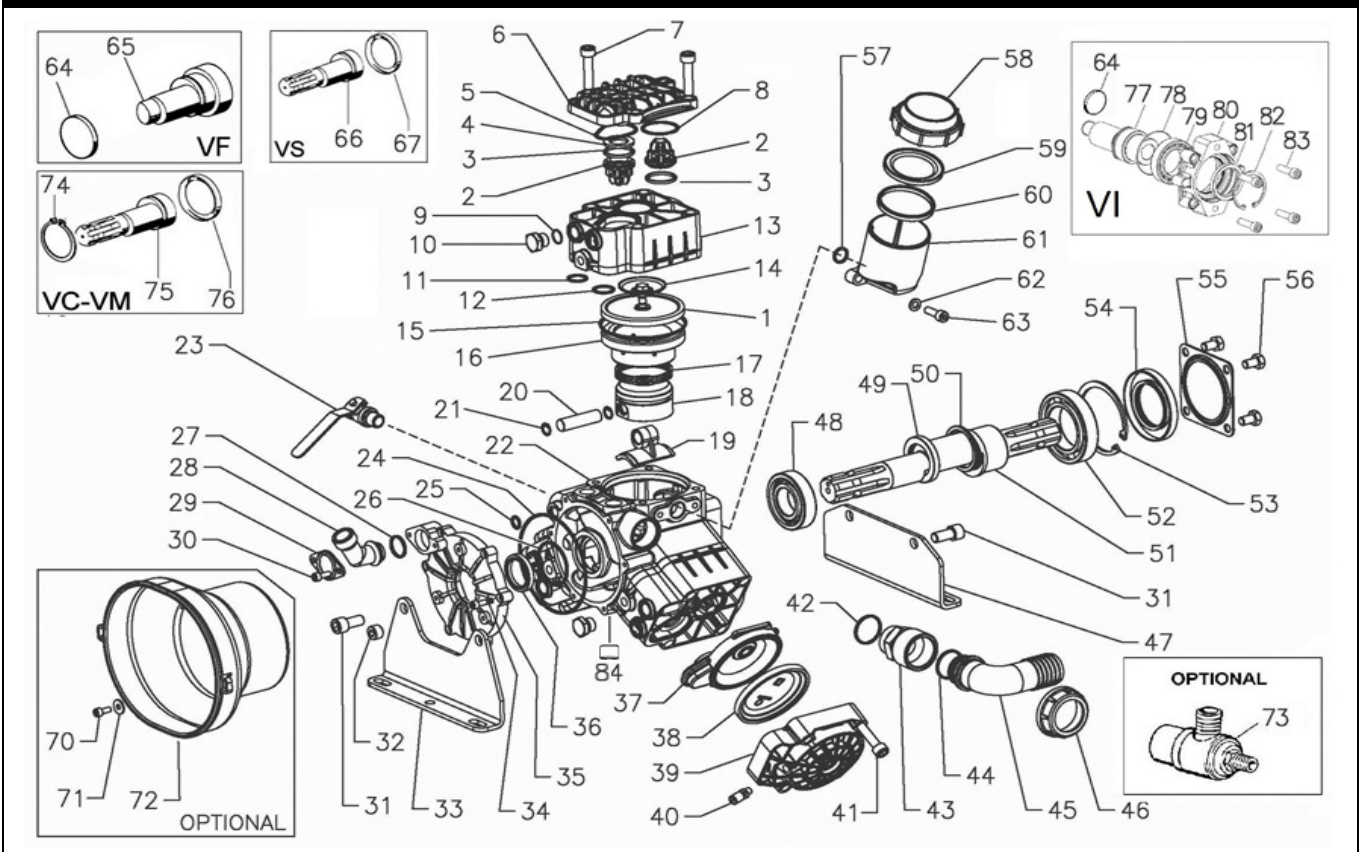

POS.	CODICE PART NO. REF.	DENOMINAZIONE - DESCRIPTION - DESCRIPTION	Q.TY	POS.	CODICE PART NO. REF.	DENOMINAZIONE - DESCRIPTION - DESCRIPTION	Q.TY
1	23.0011.31.2	PISTON DIAPHRAGM	3	38	40.0011.31.2	BALLASTER DIAPHRAGM	2
1	23.0011.33.2	VITON PISTON DIAPHRAGM	3	38	40.0011.33.2	VITON BALLASTER DIAPH.	2
1	23.0011.00.2	DESMOPAN PISTON DIAPHRAGM	3	39	23.0322.09.2	BALLASTER COVER	2
1	23.0011.37.2	HPS PISTON DIAPHRAGM	3	40	86.1605.00.2	AIR VALVE	2
2	23.9906.97.3	VALVE ASSY	6	41	86.3638.00.2	SCREW M10x110 UNI 5931	8
3	80.3247.50.2	O-RING 3,53x28,17	6	42	80.3208.00.2	O-RING 2,62X31,42	1
3	80.3247.60.2	O-RING 3,53x28,17 (KIT VITON)	6	43	23.0080.46.2	NIPPLES M36X1,5- G.1"1/2	1
4	23.0318.68.2	SPACER	3	44	80.3219.10.2	O-RING 3,0x30	1
5	80.3209.20.2	O-RING 2,62X42,52	3	45	84.0591.00.2	90° ELBOW CONNECTOR DIA.40-1,57"	1
5	80.3209.30.2	O-RING 2,62X42,52 (KIT VITON)	3	45	84.0571.00.2	90° ELBOW CONNECTOR DIA.38-1,49" (OPT.)	1
6	23.0313.09.2	HEAD COVER	1	46	82.0070.00.A	WING NUT G.1"1/2	1
7	86.3601.00.2	SCREW M10x90 UNI 5931	4	47	23.0320.61.2	MOUNTING RAIL	1
8	80.3208.30.2	O-RING 2,62X36,14	3	48	81.2846.00.2	BEARING DIA.35x72x17	1
8	80.3208.60.2	O-RING 2,62X36,14 (KIT VITON)	3	49	23.0019.76.2	RING	1
9	80.3065.00.2	O-RING 1,78X14	2	50	26.0047.76.2	RING	1
9	80.3065.10.2	O-RING 1,78X14 (KIT VITON)	2	51	23.0076.26.2	CRANKSHAFT"VD" (930)	1
10	85.2579.53.2	CAP G.3/8	2	52	81.2972.00.2	BEARING DIA.55x90x18	1
11	80.3189.00.2	O-RING 2,62x18,72	4	53	80.1430.00.2	SNAP RING DIA.90	1
11	80.3189.50.2	O-RING 2,62x18,72 (KIT VITON)	4	54	80.2253.00.2	OIL SEAL D. 55X90X7	1
12	80.3195.00.2	O-RING 2,62x20,29	3	55	17.0013.61.2	COVER	1
12	80.3195.05.2	O-RING 2,62x20,29 (KIT VITON)	3	56	86.3187.10.2	SCREW M10x16 UNI5931	4
13	23.0312.09.2	HEAD	3	57	80.3180.00.2	O-RING 2,62x15,08	1
14	23.0055.97.3	KIT DISK + SCREW INOX	3	58	28.0144.32.2	OIL FILLER CAP	1
15	80.3210.73.2	O-RING 2,62X94,92	3	59	41.0017.31.2	DIAPHRAGM OIL FILLER	1
16	23.0095.01.2	PISTON SLEEVE PA-S 830	3	60	14.0116.32.2	DIAPHRAGM SPACER	1
16	23.0075.01.2	PISTON SLEEVE PA-S 930	3	61	55.0004.32.2	OIL FILLER	1
17	81.8519.00.2	PISTON RING	6	62	84.3685.00.2	WASHER DIA.8,4x15x1,5	2
18	23.0074.09.2	PISTON	3	63	86.2683.00.2	SCREW M8x25 UNI5931	2
19	23.0005.09.2	CONROD	3	64	80.2099.50.2	CAP D.47X7 (830 VF-VI) (930 VI)	1
19	23.0045.11.2	BRONZE CONROD (OPTIONAL)	3	65	23.0028.26.2	SHAFT (830 VF)	1
20	85.2007.00.2	PISTON PIN	3	66	23.0036.26.2	SHAFT (830 VS)	1
21	80.0021.00.2	RING	6	67	80.2252.00.2	CAP D.90X8 (830 VS)	1
22	23.0203.09.2	CRANKCASE	1	70	86.2086.00.2	SCREW M6x14 UNI5931	3
23	84.5544.10.2	LEFT TAP G.3/8-G.1/2	1	71	84.3618.00.2	WASHER	3
24	80.3210.68.2	O-RING 2,62x120,32	1	72	31.1467.32.2	SAFETY CONE (OPTIONAL)	1
24	80.3210.69.2	O-RING 2,62x120,32 (KIT VITON)	1	73	24.3040.97.3	SAFETY VALVE 40bar (OPTIONAL)	1
25	80.3189.00.2	ANELLO OR 2,62x18,72	1	74	80.1377.00.2	RING (VC-VM-VF VERSIONS)	1
25	80.3189.50.2	ANELLO OR 2,62x18,72 (KIT VITON)	1	75	22.0310.26.2	SHAFT (830 VC)	1
26	80.3209.80.2	O-RING 2,62x50,47	1	75	23.0091.26.2	SHAFT (930 VC)	1
26	80.3209.85.2	O-RING 2,62x50,47 (KIT VITON)	1	75	23.0024.26.2	SHAFT (830 VM)	1
27	80.3218.00.2	O-RING 3,0x22	1	75	23.0092.26.2	SHAFT (930 VM)	1
28	31.1516.09.2	DIRECTIONAL FITTING G. 3/4	1	76	80.2263.00.2	OIL SEAL D.68X90X7 (VC-VM-VF VERSIONS)	1
29	31.1517.61.2	FLANGE	1	77	22.0328.26.2	SHAFT (830 VI)	1
30	86.2108.00.2	SCREW M6x16 UNI5931	2	77	23.0337.26.2	SHAFT (930 VI)	1
31	86.3696.00.2	SCREW M12X25 UNI5931	4	78	80.3210.67.2	O-RING 2,62X88,57	1
32	85.2585.00.2	CAP EI G.3/8	1	79	81.2914.00.2	BEARING 40X90X23	1
33	23.0319.61.2	MOUNTING RAIL	1	80	22.0333.09.2	FLANGE	1
34	86.2216.00.2	SCREW M6x25 UNI5931	6	81	80.2188.10.2	OIL SEAL 40X62X7	1
35	23.0202.09.2	CRANKCASE COVER (before 11/2018)	1	82	80.1400.00.2	RING D.62	1
35	23.0212.09.2	CRANKCASE COVER (from 12/2018)	1	83	86.3347.00.2	SCREW M10X35 UNI5931	4
36	80.2134.50.2	OIL SEAL	1	84	85.2541.00.2	PLUG DIN 906 1/4GAS [Loxael 55-14]	1
37	23.0323.32.2	LOWER BALLASTER	2				