

DIMENSIONI D'INGOMBRO - OVERALL DIMENSIONS

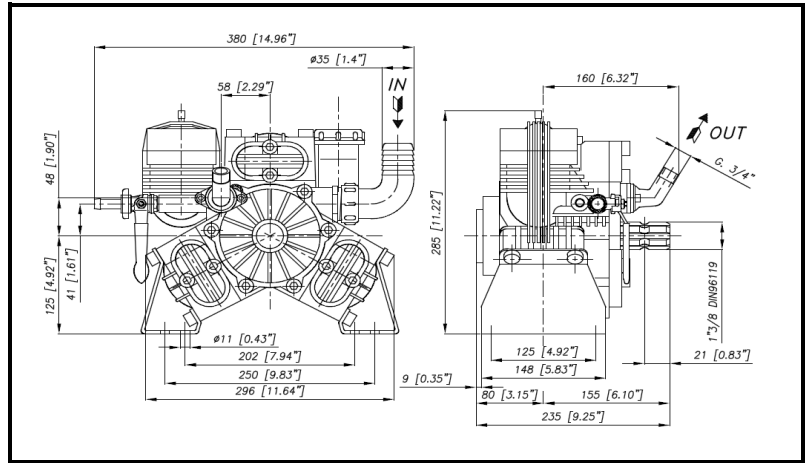

ALBERO POMPA - PUMP SHAFT

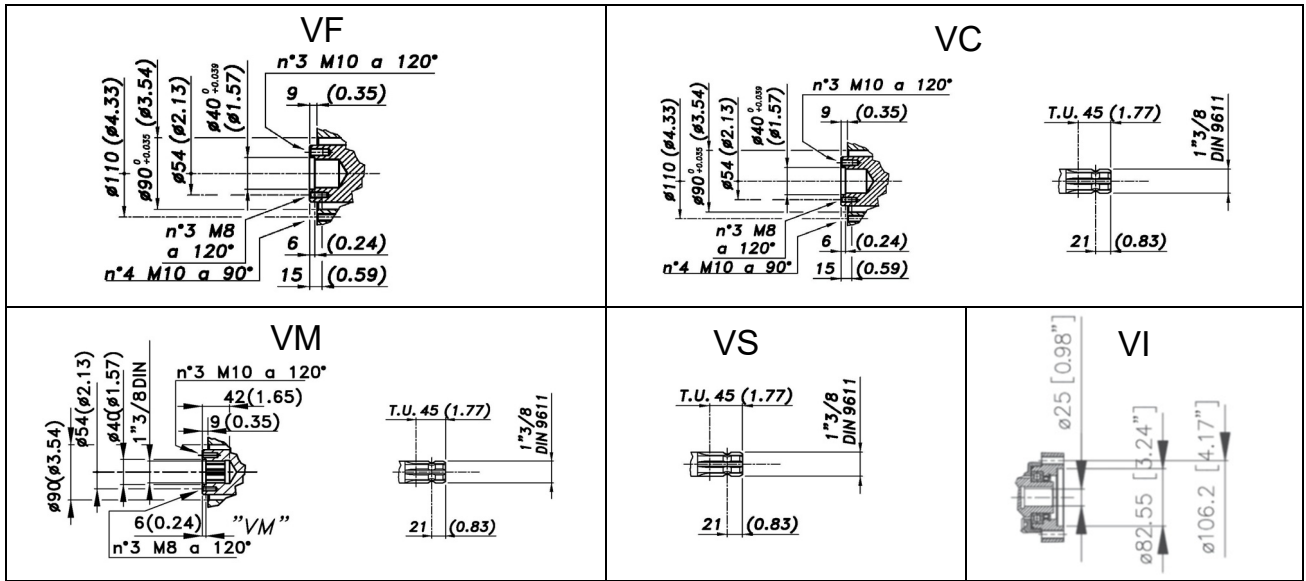

COPPIA DI SERRAGGIO - TORQUE CHART

CODICE - CODE	Q.TY	POS	N-m	Lbr.ft
23.0055.97.3	3	3	12	8,9
86.2168.00.2	2	40	10	7,4
86.2216.00.2	6	39	10	7,4
86.2730.00.2	2	28	10	7,4
86.3185.00.2	4	18	22	16,2
86.3300.00.2	6	48	44	32,5
86.3575.00.2	4	46	44	32,5
86.3590.00.2	8	32	44	32,5
86.3985.00.2	1	62	68	50,2
86.2852.00.2	4	91	12	8,9

Tolleranza di serraggio: 0/-10%
Tolerance on torque value:

INFORMAZIONI UTILI - USEFUL INFORMATION

LUBRIFICANTE - LUBRICANT:
OLIO MOTORE O SEMIIDRAULICO SAE 30
MOTOR OIL OR SEMI-HYDRAULIC OIL SAE 30

PRESSIONE ACCUMULATORE - ACCUMULATOR PRESSURE

PRESSIONE DI LAVORO - OPERATING PRESSURE	2 ÷ 5	5+10	10 + 20	20 ÷ 50
ACCUMULATORE - ACCUMULATOR	2	2 ÷ 5	5 + 7	6 ÷ 8

KIT MEMBRANE - DIAPHRAGMS KIT

KIT	23.9830.97.3 23.9830.97.A*	BUNA - N			DESMOPAN			VITON								PENTAX					
		1	45	57	1	45	57	1	44	45	49	50	36	37	57	59	1	45	57		
POSIZIONE ESPLOSO POSITION NUMBER	23.9874.97.3 23.9874.97.A*	3	6	1	3	6	1	23.9827.97.3 23.9827.97.A*	3	1	6	6	6	1	1	1	1	23.9876.97.3 23.9876.97.A*	3	6	1
QUANTITA' NEL KIT QUANTITIES INCLUDED																					

* .3: per pompe con calotta accumulatore in alluminio/for pumps with aluminum ballaster cover

* .A: per pompe con calotta accumulatore in polipropilene/for pumps with polypropylene ballaster cover

KIT POMPA/KIT VALVOLE - PUMP KIT/VALVES KIT

KIT	23.9881.97.3	KIT POMPA VM PUMP KIT VM									23.9829.97.3	KIT VALVOLE VALVE KIT					
		35	19	44	45	49	50	36	37	59		2	50	49			
POSIZIONE ESPLOSO POSITION NUMBER		1	1	1	6	6	6	1	1	1		6	6	6			
QUANTITA' NEL KIT QUANTITIES INCLUDED																	

PA 730.1

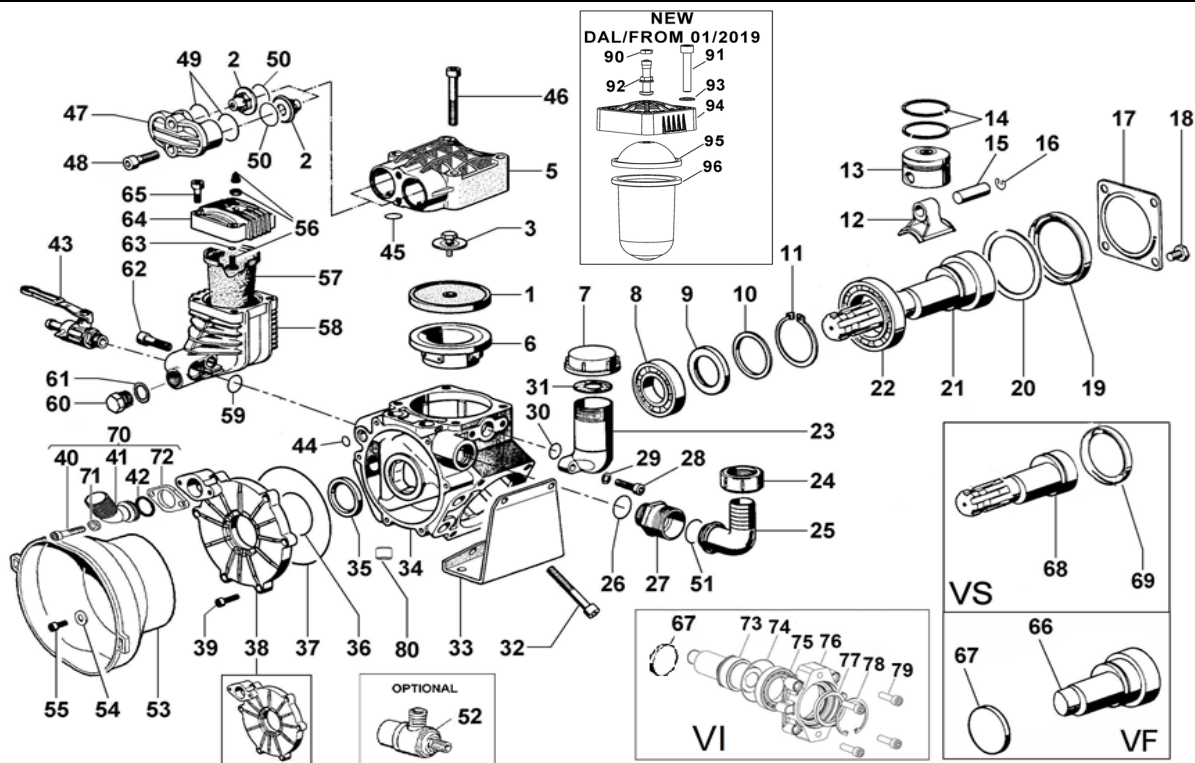

POS.	CODICE PART NO. REF.	DENOMINAZIONE - DESCRIPTION - DESCRIPTION	Q.TY	POS.	CODICE PART NO. REF.	DENOMINAZIONE - DESCRIPTION - DESCRIPTION	Q.TY
1	23.0011.31.2	PISTON DIAPHRAGM	3	43	84.5544.10.2	LEFT TAP G.3/8-G.1/2	1
1	23.0011.33.2	VITON PISTON DIAPHRAGM	3	44	80.3176.00.2	O-RING 2,62x11,91 till the 04/2016	1
1	23.0011.00.2	DESMOPAN PISTON DIAPHRAGM	3	44	80.3176.50.2	O-RING 2,62x11,91(KIT VITON) till the 04/2016	1
1	23.0011.36.2	HPS PISTON DIAPHRAGM	3	44	80.3189.00.2	O-RING 2,62x18,72 from the 05/2016	1
2	23.9805.97.3	VALVE ASSY	6	44	80.3189.50.2	O-RING 2,62x18,72(KIT VITON)from the 05/2016	1
3	23.0055.97.3	KIT DISK + SCREW INOX	3	45	80.3189.00.2	O-RING 2,62x18,72	6
5	23.0052.09.2	HEAD	3	45	80.3189.50.2	O-RING 2,62x18,72 (KIT VITON)	6
6	23.0038.01.2	PISTON SLEEVE	3	46	86.3575.00.2	SCREW M10x75 UNI5931	4
7	85.2750.00.2A	OIL FILLER CAP (before 08/2020)	1	47	23.0003.09.2	VALVE COVER	3
7	85.2750.00.2A	OIL FILLER CAP (from 09/2020)	1	48	86.3300.00.2	SCREW M10x30 UNI5931	6
8	81.2846.00.2	BEARING DIA.35x72x17	1	49	80.3219.20.2	O-RING 3,0x35	6
9	23.0019.76.2	RING	1	49	80.3219.50.2	O-RING 3,0x35 (KIT VITON)	6
10	26.0047.76.2	RING	1	50	80.3207.00.2	O-RING 2,62x29,82	6
11	80.1377.00.2	RING "VM"- "VC"	1	50	80.3207.50.2	O-RING 2,62x29,82 (KIT VITON)	6
12	23.0005.09.2	CONROD	3	51	80.3219.10.2	O-RING 3,0x30	1
12	23.0045.11.2	BRONZE CONROD (OPTIONAL)	3	52	24.3040.97.3	SAFETY VALVE 40bar (OPTIONAL)	1
13	23.0040.09.2	PISTON	3	53	31.1467.32.2	SAFETY CONE (OPTIONAL)	1
14	81.8514.00.2	PISTON RING	6	54	84.3618.00.2	WASHER (OPTIONAL)	3
15	85.2007.00.2	PISTON PIN	3	55	86.2086.00.2	SCREW M6x14 UNI5931 (OPTIONAL)	3
16	80.0021.00.2	RING	6	56	86.1608.50.2	AIR VALVE (BEFORE 01-19)	1
17	17.0013.61.2	COVER	4	57	23.0041.31.2	BALLASTER DIAPHRAGM (BEFORE 01-19)	1
18	86.3187.10.2	SCREW M10x16 UNI5931	4	57	23.0041.33.2	VITON BALLASTER DIAPH. (BEFORE 01-19)	1
19	80.2264.10.2	OIL SEAL	1	57	23.0041.36.2	HPS BALLASTER DIAPH. (BEFORE 01-19)	1
20	17.0024.76.2	SPACER	1	58	23.0039.09.2	DAMPER BODY	1
21	22.0310.26.2	CRANKSHAFT"VC"(SEE OVERALL DIMENSIONS)	1	59	80.3182.00.2	O-RING 2,62x17,13	1
21	23.0024.26.2	CRANKSHAFT VERSION "VM" (1"3/8 M-F)	1	59	80.3182.50.2	O-RING 2,62x17,13 (KIT VITON)	1
22	81.2972.00.2	BEARING DIA.55x90x18	1	60	85.2579.53.2	CAP G.3/8	1
23	23.0008.32.2	OIL FILLER	1	61	82.4107.00.2	GASKET DIA.16,5x23x1	1
24	82.0070.00.2	WING NUT G.1"1/2	1	62	86.3985.00.2	SCREW M12x50 UNI5931	1
25	84.0570.00.2	90° ELBOW CONNECTOR DIA.35-1,37"	1	63	80.3213.00.2	O-RING 3,0x6 (BEFORE 01-19)	1
25	84.0561.00.2	90° ELBOW CONNECTOR DIA.30-1,18" (OPT.)	1	64	11.0004.09.2	BALLASTER COVER (BEFORE 01-19)	1
25	84.0566.00.2	90° ELBOW CONNECTOR DIA.32-1,25" (OPT.)	1	65	86.2730.00.2	SCREW M8x30 UNI5931 (BEFORE 01-19)	4
25	84.0571.00.2	90° ELBOW CONNECTOR DIA.38-1,49" (OPT.)	1	66	23.0028.26.2	CRANKSHAFT"VF"(SEE OVERALL DIMENSIONS)	1
25	84.0591.00.2	90° ELBOW CONNECTOR DIA.40-1,57" (OPT.)	1	67	80.2099.50.2	CAP 47X7	1
26	80.3207.00.2	O-RING 2,62x29,82	1	68	23.0036.26.2	CRANKSHAFT VERSION "VS" (1"3/8 M)	1
27	83.5090.18.2	NIPPLES G.1"-G.1"1/2	1	69	80.2156.00.2	CAP	1
28	86.2730.00.2	SCREW M8x30 UNI5931	2	70	31.8917.97.3	FITTING KIT G. 3/4	1
29	84.3685.00.2	WASHER DIA.8,4x15x1,5	2	71	84.3585.00.2	WASHER D.6	2
30	80.3180.00.2	O-RING 2,62x15,08	1	72	31.1517.61.2	FLANGE LOCK FITTING	1
31	82.4120.00.2	GASKET DIA.45x19x1,5 (before 08/2020)	1	73	22.0328.26.2	SHAFT "VI"	1
31	23.0097.31.2	OIL FILLING DIAPHRAGM (from 09/2020)	1	74	80.3210.67.2	O-RING 2,62x88,57	1
32	86.3590.00.2	SCREW M10x80 UNI 5931	8	75	81.2914.00.2	BEARING 40X90X23	1
33	23.0033.61.2	MOUNTING RAIL	2	76	22.0333.09.2	FLANGE	1
34	23.0001.09.2	CRANKCASE till the 04/2016	1	77	80.2188.10.2	OIL SEAL 40X62X7	1
34	23.0201.09.2	CRANKCASE from the 05/2016	1	78	80.1400.00.2	RING D.62	1
35	80.2134.50.2	OIL SEAL	1	79	86.3347.00.2	SCREW M10X35 UNI5931	4
36	80.3209.80.2	O-RING 2,62x50,47	1	80	85.2541.00.2	PLUG DIN 906 1/AGAS [Loxeal 55-14]	1
36	80.3209.85.2	O-RING 2,62x50,47 (KIT VITON)	1	90	86.1611.00.2	AIR VALVE NUT (FROM 01-19)	1
37	80.3210.68.2	O-RING 2,62x120,32	1	91	86.2852.00.2	SCREW M8X45 (FROM 01-19)	4
37	80.3210.69.2	O-RING 2,62x120,32 (KIT VITON)	1	92	86.1609.00.2	AIR VALVE (FROM 01-19)	1
38	23.0046.09.2	CRANKCASE COVER (till the 06/1999)	1	93	84.3685.00.2	WASHER D.8,4x15x1,5 (FROM 01-19)	4
38	23.0006.09.2	CRANKCASE COVER (till the 04/2016)	1	94	11.0183.32.2	BALLASTER COVER (FROM 01-19)	1
38	23.0212.09.2	CRANKCASE COVER (from the 05/2016)	1	95	10.0041.31.2	SUP. BALLASTER DIAPHRAGM (FROM 01-19)	1
39	86.2216.00.2	SCREW M6x25 UNI5931	6	96	23.0094.31.2	INF.BALLASTER DIAPHRAGM (FROM 01-19)	1
40	86.2108.00.2	SCREW M6x16 UNI5931	2				
41	31.1516.09.2	DIRECTIONAL FITTING G. 3/4	1				
42	80.3218.00.2	O-RING 3,0x22	1				