

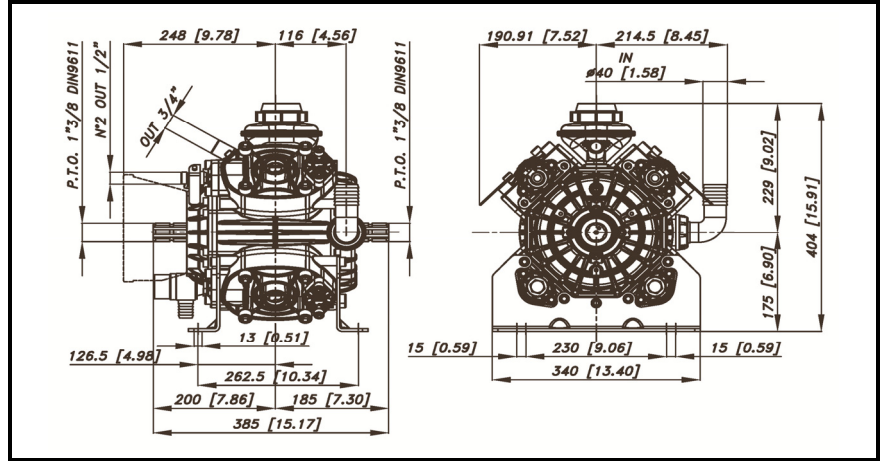

DIMENSIONI D'INGOMBRO - OVERALL DIMENSIONS

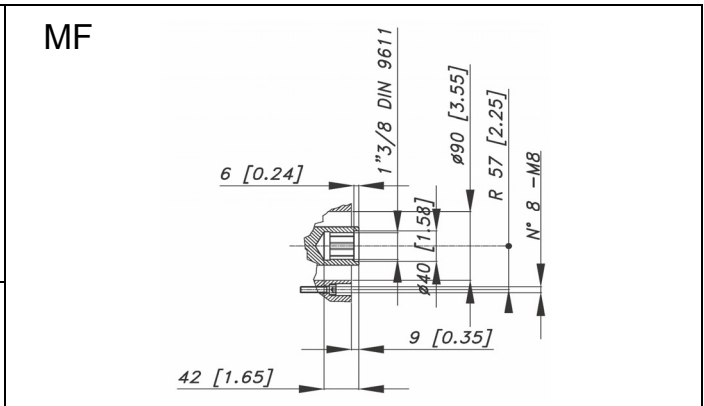

ALBERO POMPA - PUMP SHAFT

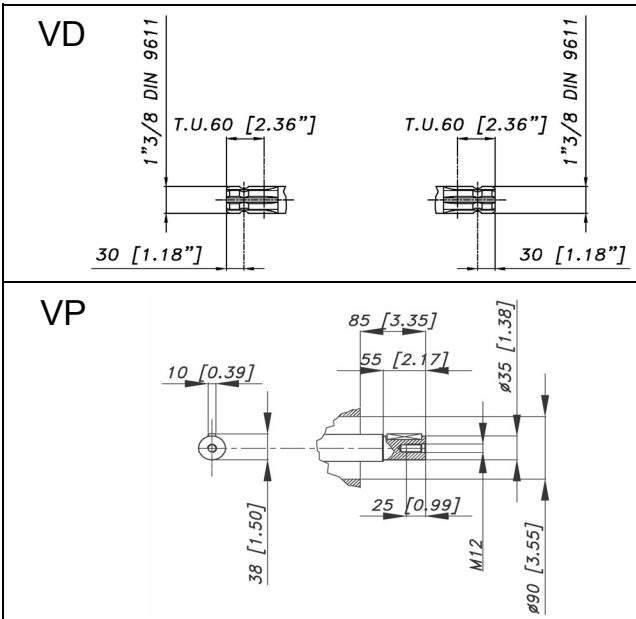

COPPIA DI SERRAGGIO - TORQUE CHART				
CODICE - CODE	Q.TY	POS	N.m	Lbr.ft
86.2730.00.2	20	3	22	16,2
86.2752.00.2	8	4	22	16,2
86.3265.00.2	9	12	44	32,5
86.3347.00.2	1	15	44	32,5
41.9835.97.3	4	22	25	18,5
86.4250.00.2	16	45	108	79,7
86.3300.00.2	16	52	44	32,5
85.2543.50.2	1	66	22	16,2

Tolleranza di serraggio: 0/-10%
Tolerance on torque value:

INFORMAZIONI UTILI USEFUL INFORMATION				
LUBRIFICANTE - LUBRICANT: OLIO MOTORE O SEMIIDRAULICO SAE 30 MOTOR OIL OR SEMI-HYDRAULIC OIL SAE 30				
PRESSIONE ACCUMULATORE ACCUMULATOR PRESSURE				
PRESSIONE DI LAVORO - OPERATING PRESSURE	2 ÷ 5	5+10	10 ÷ 20	20 ÷ 50
ACCUMULATORE ACCUMULATOR	2	2 ÷ 5	5 ÷ 7	6 ÷ 8

KIT MEMBRANE - DIAPHRAGMS KIT

KIT	BUNA - N			DESMPAN			VITON					PENTAX			
	1	9	59	1	9	59	1	9	31	32	47	48	59	1	9
POSIZIONE ESPLOSO POSITION NUMBER	41.9875.97.3			41.9876.97.3			41.9877.97.3					41.9878.97.3			
QUANTITA' NEL KIT QUANTITIES INCLUDED	4			4			4					4			

KIT POMPA/KIT VALVOLE - PUMP KIT/VALVES KIT

KIT	KIT POMPA VD PUMP KIT VD							KIT POMPA VP-MF PUMP KIT VM							KIT VALVOLE VALVE KIT			
	55	30	59	31	32	33	47	48	55	63-71	59	31	32	33	47	48	2	47
POSIZIONE ESPLOSO POSITION NUMBER	41.9882.97.3							41.9884.97.3							41.9870.97.3			
QUANTITA' NEL KIT QUANTITIES INCLUDED	1							1							8			

PBO 1440-1540

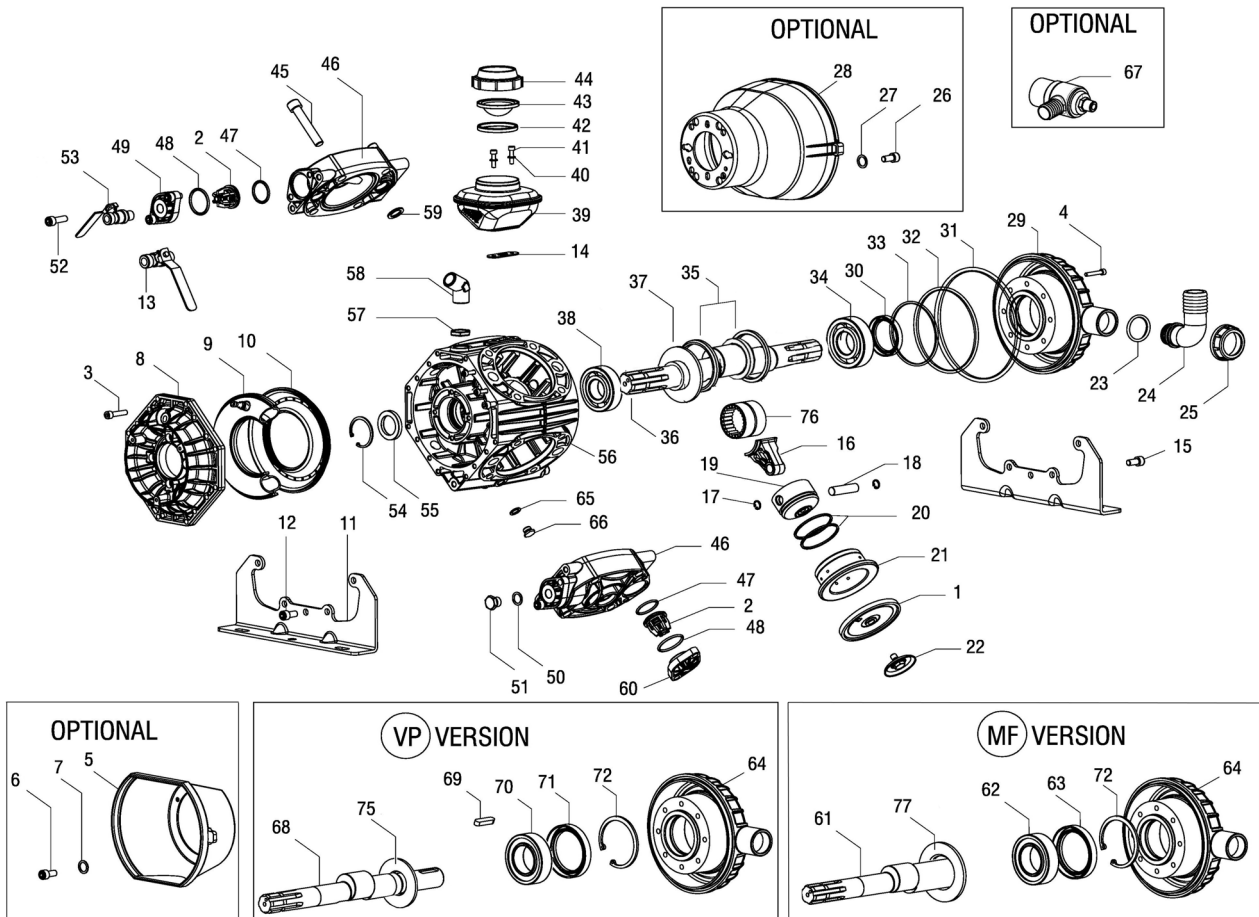

POS.	CODICE PART NO. REF.	DENOMINAZIONE - DESCRIPTION - DESCRIPTION	Q.TY	POS.	CODICE PART NO. REF.	DENOMINAZIONE - DESCRIPTION - DESCRIPTION	Q.TY
1	95.0040.31.2	BUNA-N PISTON DIAPHRAGM	4	34	81.2913.00.2	BEARING 40X90X23	1
1	95.0040.33.2	VITON PISTON DIAPHRAGM (OPTIONAL)	4	35	14.0015.76.2	CONROD HOLDING RING	2
1	95.0040.00.2	DESMPAN PISTON DIAPHRAGM (OPTIONAL)	4	36	41.0167.26.2	CRANKSHAFT "VD" (1"3/8 M-M)	1
1	95.0040.36.2	HPS PISTON DIAPHRAGM (OPTIONAL)	4	37	41.0153.61.2	SHAFT RING	1
2	35.9802.97.3	VALVES ASSEMBLY	8	38	81.2870.00.2	ROLLER BEARING 35X80X21	1
3	86.2730.00.2	SCREW M8x30 UNI 5931	20	39	40.9801.97.3	OIL FILLER ASSY	1
4	86.2752.00.2	SCREW M8x35 UNI 5931	8	40	84.3585.00.2	WASHER DIA.6 UNI 6592	2
5	31.1466.32.2	PLAIN SAFETY CONE (OPTIONAL)	1	41	86.2216.00.2	BOLT M6X25 UNI 5931	2
6	86.1846.00.2	SCREW M5,5x16 UNI 6954 (OPTIONAL)	3	42	14.0116.32.2	DIAPHRAGM SPACER	1
7	84.3560.00.2	WASHER DIA. 5,5x15x1,6 (OPTIONAL)	34	43	41.0017.31.2	OIL FILLER DIAPHRAGM	1
8	41.0105.09.2	BALLASTER COVER	1	44	28.0144.32.2	OIL FILLER COVER	1
9	41.0120.97.3	NBR BALLASTER DIAPHRAGM	1	45	86.4250.00.2	BOLT M14x70 UNI 5931	16
10	41.0104.09.2	LOWER BALLASTER	1	46	41.0111.09.2	PUMP HEAD	4
11	41.0113.61.2	MOUNTING RAIL	2	47	80.3251.00.2	O-RING DIA.3,53x32,93	8
12	86.3265.00.2	SCREW M10x25 UNI 5931	5	47	80.3251.50.2	O-RING DIA.3,53x32,93 (KIT VITON)	8
13	84.5544.10.2	LEFT TAP G.3/8"-G.1/2"	1	48	80.3262.00.2	O-RING DIA.3,53x41,28	8
14	14.0017.72.2	GASKET	1	48	80.3262.50.2	O-RING DIA.3,53x41,28 (KIT VITON)	8
15	86.3265.00.2	SCREW M10x25 UNI 5931	5	49	41.0110.09.2	VALVE COVER G.3/8"	4
16	41.0165.09.2	CONROD	4	50	82.4107.00.2	GASKET	2
17	80.0021.00.2	RING DIA.15	8	51	85.2579.00.2	CAP G.3/8"	2
18	85.2007.00.2	PISTON PIN DIA.15x54	4	52	86.3300.00.2	BOLT M10x30 UNI 5931	16
19	41.0025.09.2	PISTON - PBO 1440	4	53	84.5544.00.2	RIGHT TAP G.3/8"-G.1/2"	1
19	37.0016.09.2	PISTON - PBO 1540	4	54	80.1369.00.2	SNAP RING DIA.52	1
20	81.8524.00.2	PISTON RING - PBO 1440	8	55	80.2143.10.2	OIL SEAL DIA.35x52x7	1
20	81.8527.00.2	PISTON RING - PBO 1540	8	56	41.0133.09.2	PUMP CRANKCASE	1
21	41.0026.01.2	PISTON SLEEVE - PBO 1440	4	57	81.4909.00.2	BRASS NUT G.3/4"	1
21	43.0015.01.2	PISTON SLEEVE - PBO 1540	4	58	83.5063.28.2	60° ELBOW CONNECTOR G.3/4	1
22	41.9835.97.3	KIT DISK + SCREW INOX	4	59	80.3200.00.2	O-RING DIA.2,62x22,22	8
23	80.3219.10.2	O-RING DIA. 3.0x30	1	59	80.3200.50.2	O-RING DIA.2,62x22,22 (KIT VITON)	8
24	84.0591.00.2	90° ELBOW CONNECTOR DIA.40-1,57"	1	60	41.0109.09.2	VALVE COVER	4
25	82.0070.00.2	WING NUT G.1"1/2	1	61	41.0151.26.2	CRANKSHAFT "MF" (1"3/8 M-F)	1
26	86.1846.00.2	SCREW M5,5x16 UNI 6954 (OPTIONAL)	4	62	81.2970.00.2	ROLLER BEARING 50X90X23	1
27	84.3560.00.2	WASHER DIA.5,5x15x1,6 (OPTIONAL)	4	63	80.2235.00.2	OIL SEAL DIA.50X80X10	1
28	31.1482.32.2	PLAIN SAFETY CONE L.180 (OPTIONAL)	1	64	41.0116.09.2	INLET COVER "VP-MF"	1
28	31.1468.32.2	PLAIN SAFETY CONE L.135 (OPTIONAL)	1	65	82.4079.00.2	WASHER	1
29	41.0112.09.2	INLET COVER "VD"	1	66	85.2543.50.2	CAP G.1/4"	1
30	80.2190.00.2	OIL SEAL DIA.40x72x10 "VD"	1	67	24.3050.97.3	SAFETY VALVE 50 BAR (OPTIONAL)	1
31	80.3295.00.2	O-RING DIA.3,53x190,10	1	68	41.0152.26.2	CRANKSHAFT "VP" (SOLID SHAFT Ø35mm)	1
31	80.3295.50.2	O-RING DIA.3,53x190,10 (KIT VITON)	1	69	80.6580.00.2	KEY 10X8X50 UNI 6604	1
32	80.3210.70.2	O-RING DIA.2,62x126,67	1	70	81.2912.00.2	ROLLER BEARING DIA.40X90X23	1
32	80.3210.75.2	O-RING DIA.2,62x126,67 (KIT VITON)	1	71	80.2189.70.2	OIL SEAL DIA. 40X80X8	1
33	80.3291.00.2	O-RING DIA.3,53x88,5	1	72	80.1428.00.2	SNAP RING DIA.80 UNI 7437	1
34	81.2913.00.2	BEARING 40X90X23	1	75	41.0170.19.2	SHAFT RING VP-VP1	1
35	14.0015.76.2	CONROD HOLDING RING	2	76	81.2950.00.2	NEEDLE ROLLER BEARING	2
				77	41.0171.19.2	SHAFT RING ("MF")	1