

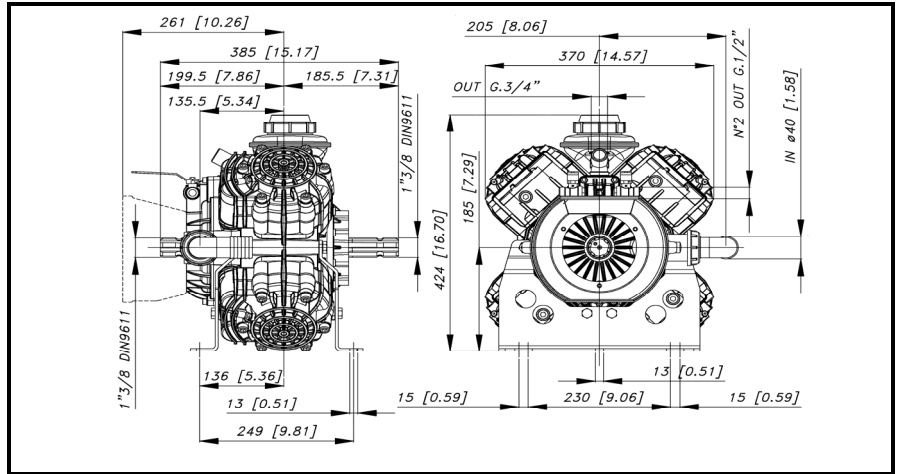

DIMENSIONI D'INGOMBRO - OVERALL DIMENSIONS



ALBERO POMPA - PUMP SHAFT

VD

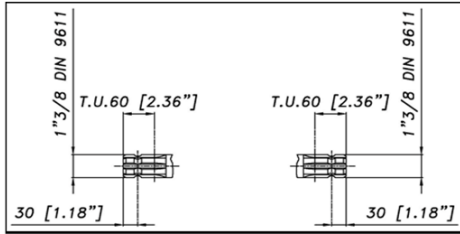

VM

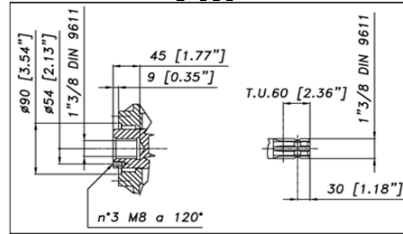

VP

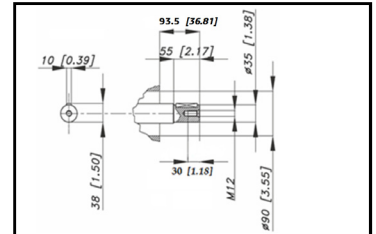

COPPIA DI SERRAGGIO - TORQUE CHART

CODICE - CODE	Q.TY	POS	N-m	Lbr-ft
86.2562.00.2	8	11	22	16.2
41.9835.97.3	4	3	25	18.4
86.4139.00.2	2	14	68	50.2
86.3740.00.2	2	16	68	50.2
86.2440.00.2	2	31	7	5.2
86.4025.10.2	2	33	68	50.2
81.4706.00.2	2	34	68	50.2
86.2428.00.2	6	39	7	5.2
86.2428.00.2	8	51	7	5.2
86.3638.00.2	8	56	44	32.5
86.3600.00.2	16	57	44	32.5
86.2216.00.2	2	64	7	5.2
86.2547.00.2	2	70	22	16.2

Tolleranza di serraggio: 0/-10%
Tolerance on torque value: 0/-10%

INFORMAZIONI UTILI
USEFUL INFORMATION

LUBRIFICANTE - LUBRICANT:

OLIO MOTORE O SEMIIDRAULICO SAE 75-W90
MOTOR OIL OR SEMI-HYDRAULIC OIL SAE 75-W90

PRESSIONE ACCUMULATORE
ACCUMULATOR PRESSURE

PRESSIONE DI LAVORO - OPERATING PRESSURE	2 + 5	5+10	10 + 20	20 + 50
ACCUMULATORE ACCUMULATOR	2	2 + 5	5 + 7	6 + 8

KIT MEMBRANE/KIT VALVOLE - DIAPHRAGMS KIT /VALVES KIT

KIT	BUNA - N 40.9802.97.3 DESMOPAN 40.9803.97.3 HPS 40.9804.97.3 PENTAX 40.9811.97.3						VITON 40.9805.97.3								40.9808.97.3	KIT VALVOLE VALVE KIT				
	1	46	53	58	60	61	1	46	53	58	60	61	42	43		44	77	78	2	60
POSIZIONE ESPLOSO POSITION NUMBER	1	46	53	58	60	61	1	46	53	58	60	61	42	43	44	77	78	2	60	61
QUANTITA' NEL KIT QUANTITIES INCLUDED	4	8	4	4	8	16	4	8	4	4	8	16	1	1	1	1	1	16	8	16

KIT POMPA- PUMP KIT

KIT	40.9806.97.3	KIT POMPA VD PUMP KIT VD										40.9807.97.3	KIT POMPA VM PUMP KIT VM													
		46	58	60	61	42	43	44	12	20	24		77	78	46	58	60	61	42	43	44	73	20	24	77	78
POSIZIONE ESPLOSO POSITION NUMBER		46	58	60	61	42	43	44	12	20	24	77	78		46	58	60	61	42	43	44	73	20	24	77	78
QUANTITA' NEL KIT QUANTITIES INCLUDED		8	4	8	4	16	1	1	1	1	1	1	1		8	4	8	16	1	1	1	1	1	1	1	1

PPS 1613 - 1615

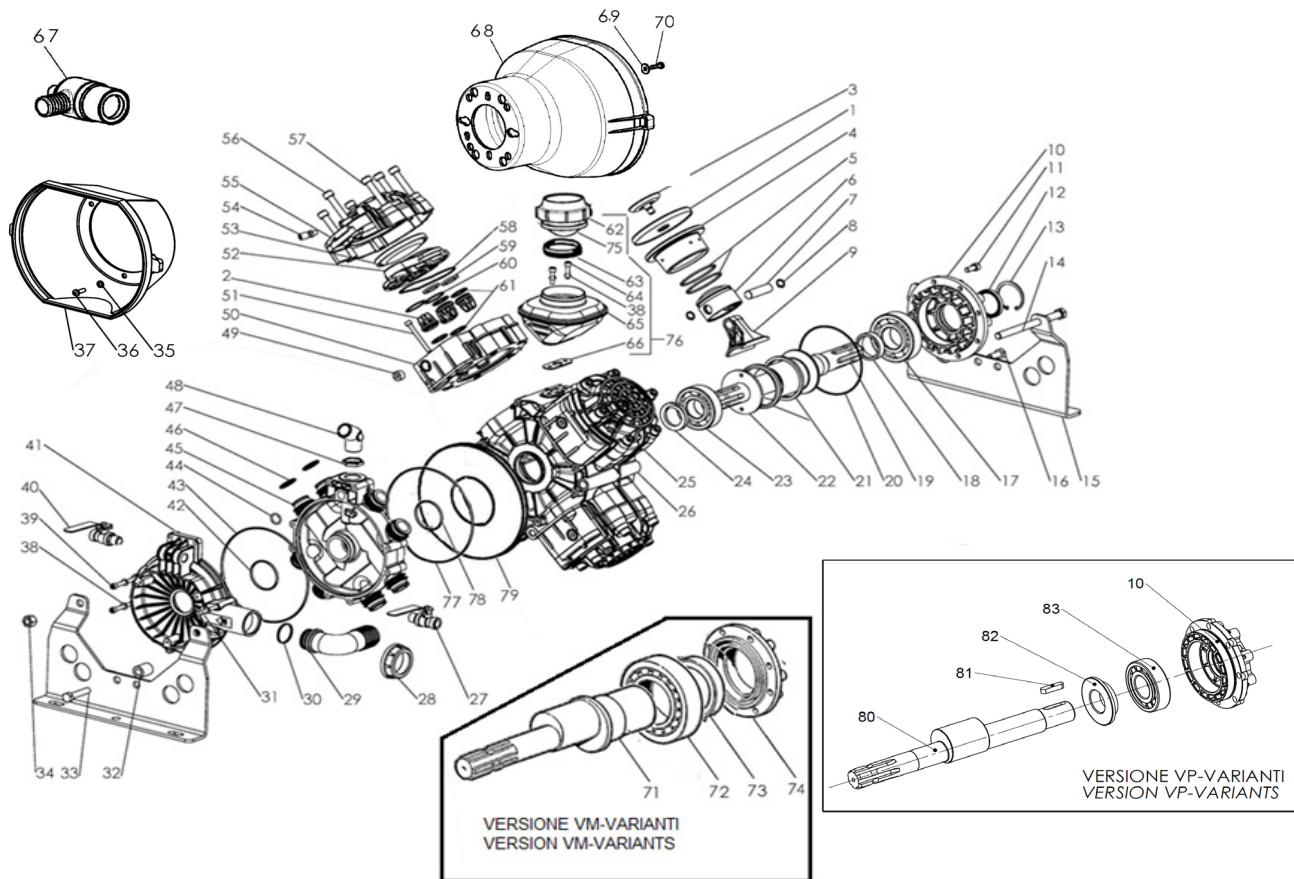

POS.	CODICE PART NO. REF.	DENOMINAZIONE - DESCRIPTION - DESCRIPTION	Q.TY	POS.	CODICE PART NO. REF.	DENOMINAZIONE - DESCRIPTION - DESCRIPTION	Q.TY
1	95.0040.31.2	BUNA-N PISTON DIAPHRAGM	4	42	80.3270.50.2	O-RING 3,53X49,2 VITON	1
1	95.0040.33.2	VITON PISTON DIAPHRAGM (OPTIONAL)	4	43	80.3292.50.2	O-RING 3,53X171,05 VITON	1
1	95.0040.00.2	DESMOPAN PISTON DIAPHRAGM (OPTIONAL)	4	44	80.3217.40.2	O-RING 3,0X16 VITON	1
1	95.0040.36.2	HPS PISTON DIAPHRAGM (OPTIONAL)	4	45	40.0004.32.2	MANIFOLD	1
1	95.0040.37.2	PENTAX PISTON DIAPHRAGM (OPTIONAL)	4	46	80.3204.50.2	O-RING 2,62X23,81 VITON	8
2	40.9800.97.3	VALVES ASSEMBLY	16	47	81.4909.00.2	NUT G.3/4 OT.	1
3	41.9835.97.3	KIT DISK + SCREW INOX	4	48	83.5063.28.2	60° ELBOW CONNECTOR G.3/4	1
4	41.0026.01.2	PISTON SLEEVE (PPS 1613)	4	49	85.2589.00.2	CAP G.3/8	4
4	43.0015.01.2	PISTON SLEEVE (PPS 1615)	4	50	40.0002.32.2	PUMP HEAD	4
5	81.8524.00.2	PISTON RING (PPS 1613)	8	51	86.2428.00.2	SCREW TCEI M6X65	8
5	81.8527.00.2	PISTON RING (PPS 1615)	8	52	40.0003.32.2	LOWER BALLASTER	4
6	41.0025.09.2	PISTON (PPS 1613)	4	53	40.0011.31.2	BUNA-N BALLASTER DIAPHRAGM	4
6	37.0016.09.2	PISTON (PPS 1615)	4	54	40.0011.33.2	VITON BALLASTER DIAPHRAGM (OPTIONAL)	4
7	85.2007.00.2	PIN 15x54	4	53	86.1605.00.2	AIR VALVE	4
8	80.0021.00.2	SNAP RING	8	55	40.0014.09.2	LEFT BALLASTER COVER	2
9	41.0047.11.2	CONROD	4	56	86.3638.00.2	SCREW TCEI M10X110	8
10	48.0003.09.2	BEARING COVER VD/VP (M8 version)	1	57	86.3600.00.2	SCREW TCEI M10X95	16
10	48.0034.09.2	BEARING COVER VD/VP (M10 version)	1	58	40.0022.33.2	SHAPED O-RING VITON	4
11	86.2562.00.2	SCREW TCEI M8X20 (M8 version)	8	59	40.0015.61.2	SPACER	8
11	86.3216.00.2	SCREW TCEI M10X20 (M10 version)	8	60	80.3208.05.2	O-RING 2,62X31,42 VITON	8
12	80.2178.00.2	OIL SEAL DIA.40x52x7	1	61	80.3205.60.2	O-RING R 2,62X25,07 VITON	16
13	80.1369.00.2	RING D.52	1	62	28.0144.32.2	OIL FILLER COVER	1
14	86.4139.00.2	SCREW TE M12X160	2	63	14.0116.32.2	SPACER	1
15	40.0009.61.2	MOUNTING RAIL	2	64	86.2216.00.2	SCREW TCEI M6X25	2
16	86.3740.00.2	SCREW TE M12X30	2	65	40.9801.97.3	ASSEMBLY OIL FILLER	1
17	81.2913.00.2	BEARING DIA.40X90X23	1	66	14.0017.72.2	GASKET	1
18	48.0008.41.2	SPACER	1	67	24.3050.97.3	SAFETY VALVE 50 BAR (OPTIONAL)	1
19	41.0033.26.2	SHAFT	1	68	31.1482.32.2	PLAIN SAFETY CONE L.180 (OPTIONAL)	1
20	80.3210.68.2	O-RING DIA.2,62X120,32	1	68	31.1468.32.2	PLAIN SAFETY CONE L.135 (OPTIONAL)	1
21	14.0015.76.2	CONROD HOLDING RING	2	69	84.3696.00.2	WASHER DIA. 8.4 (OPTIONAL)	2
22	41.0023.61.2	SHAFT RING	1	70	86.2547.00.2	SCREW TCEI M8X18 (OPTIONAL)	2
23	81.2867.00.2	BEARING DIA.35X80X21	1	71	40.0017.26.2	SHAFT VM	1
24	80.2143.10.2	OIL SEAL DIA.35X52X7	1	72	81.3020.00.2	BEARING 70X125X24	1
25	40.0006.09.2	RIGHT BALLASTER COVER	2	73	80.2264.10.2	OIL SEAL DIA.68X90X10	1
26	40.0001.09.2	CARTER (M8 version)	1	74	48.0004.09.2	BEARING COVER VM (M8 version)	1
26	40.0028.09.2	CARTER (M10 version)	1	74	48.0035.09.2	BEARING COVER VM (M10 version)	1
27	84.5544.00.2	RIGHT TAP G.3/8-G.1/2	1	75	41.0017.31.2	DIAPHRAGM OIL FILLER	1
28	82.0070.00.A	WING NUT G.1"1/2	1	76	40.9809.97.3	OIL FILLER KIT	1
29	84.0591.00.2	90° ELBOW CONNECTOR DIA.40-1,57"	1	77	80.3291.12.2	O-RING 3.53X132,9 VITON	1
30	80.3219.10.2	O-RING DIA.3.0x30	1	78	80.3283.71.2	O-RING 3.53X68,26 VITON	1
31	86.2440.00.2	SCREW TCEI M6X100	2	79	40.0019.68.2	DISK	1
32	40.0018.75.2	SPACER	2	80	41.0138.26.2	SHAFT VP	1
33	86.4025.10.2	SCREW TE M12X55	2	81	80.6579.00.2	TAB 10x8x40 UNI 6604	1
34	81.4706.00.2	NUT M12	2	82	41.0170.19.2	SHAFT RING D.40x85x18.5	1
35	84.3560.00.2	WASHER DIA.5,5x15x1,6 (OPTIONAL)	3	83	81.2912.00.2	CYLINDRICAL ROLLER BEARING 40X90X23 (VP)	1
36	86.1846.00.2	SCREW TCTC 5.5x16 (OPTIONAL)	3				
37	31.1466.32.2	PLAIN SAFETY CONE (OPTIONAL)	1				
38	84.3585.00.2	WASHER DIA.6	10				
39	86.2428.00.2	SCREW TCEI M6X65	6				
40	84.5544.10.2	LEFT TAP G.3/8-G.1/2	1				
41	40.0005.32.2	COVER	1				