

# PISTON PUMPS CHX Series

**IDROMECCANICA  
BERTOLINI**



**Operation,  
maintenance and  
repair manual**

**CHX Series  
Pumps**

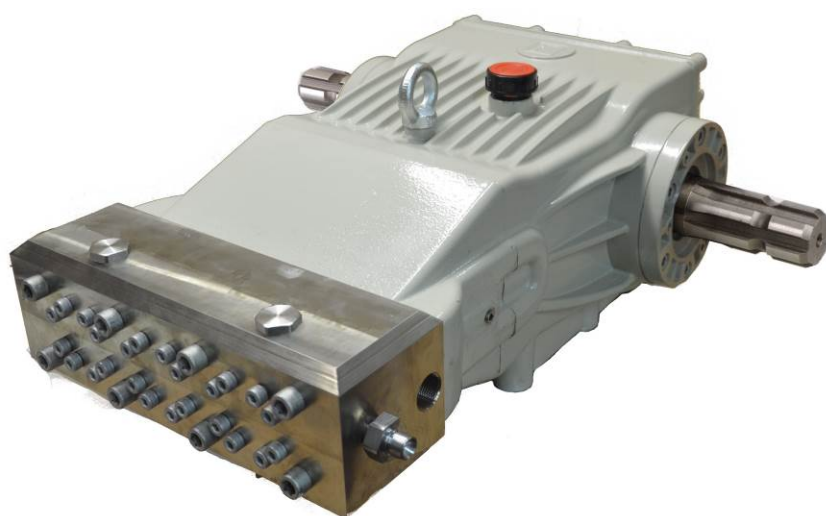

**EN**



**IDROMECCANICA  
BERTOLINI**

Reggio Emilia - Italy

Via F.lli Cervi 35/1 42124 REGGIO EMILIA - ITALY

## MANUFACTURER IDENTIFICATION DATA:

**Manufacturer:** IDROMECCANICA BERTOLINI S.p.A.  
**Address:** Via F.lli Cervi 35/1  
42124 REGGIO EMILIA - ITALY  
Tel. +39 0522 306641 Fax +39 0522 306648  
E-mail: [email@bertolinipumps.com](mailto:email@bertolinipumps.com)  
Internet: [www.bertolinipumps.com](http://www.bertolinipumps.com)

**Release:** July 2018  
**Revised on:** 1 June 2019

“**BERTOLINI**” thanks you for your preference. The product you have purchased is the result of the most modern technology and has been manufactured with materials able to ensure the best quality, durability and functionality.

Thank you for your confidence in us.

Please read this manual carefully and always keep it within easy reach. You will find it useful in resolving any problem you may have concerning the characteristics and functionality of the product.

***Thank you for having chosen “Bertolini”***

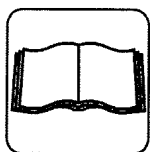

We at ***Idromeccanica Bertolini S.p.A.*** recommend that you read this operation and maintenance manual before installing and using the pump. Keep it within easy reach for further reference when required. This manual is an integral part of the pump itself.

The pump user and plant engineer are obliged to know and comply with the pertinent laws in force in the country where the pump is used. They are also required to follow the instructions in this manual with care.



















# TABLE OF CONTENTS

<b>1-GENERAL SAFETY REGULATIONS</b> .....	<b>5</b>
<b>2-DESCRIPTION OF THE PRODUCT</b> .....	<b>6</b>
<b>3-TECHNICAL FEATURES</b> .....	<b>7</b>
3.1 Identification of components.....	8
3.2 Instructions for use.....	9
<b>4-INSTALLATION</b> .....	<b>10</b>
4.1 Pump connection to the frame .....	10
4.3 Pump-motor coupling .....	10
4.3 V-belt transmission .....	11
4.4 Hydraulic connections .....	11
4.5 Filtering and feeding circuit .....	12
4.6 High pressure circuit.....	13
4.7 General installation layouts .....	14
<b>5- SAFETY AND FAULT PREVENTION DEVICES</b> .....	<b>16</b>
5.2 Fault prevention .....	16
5.2 A) Protection against overpressure .....	16
5.2 B) Protection against abrasive particles .....	16
5.2 D) Protection against overheating .....	19
5.2 E) Protection against insufficient or no water supply .....	19
5.2 F) Energy saving / correct use of the pump .....	19
<b>6- FAQ</b> .....	<b>21</b>
<b>7- PUTTING INTO SERVICE</b> .....	<b>22</b>
7.1 Start-up .....	23
7.2 Use .....	23
7.3 Leaking water from the gaskets.....	23
7.4 How to stop the pump .....	23
<b>8- TROUBLESHOOTING</b> .....	<b>25</b>
<b>9- WARRANTY</b> .....	<b>26</b>
<b>10- ROUTINE MAINTENANCE</b> .....	<b>27</b>
10.1 Maintenance of drive mechanism and lubrication .....	27
10.2 Hydraulic circuit maintenance.....	27
10.3 Disassembly of head and sleeves .....	28
10.4 Replacement of the suction and delivery valves.....	29
10.4 A) Suction valves .....	29
10.4 B) Delivery valves .....	30

10.5 Replacement of high-pressure gaskets.....	31
10.6 Complete re-assembly of the suction-delivery valves .....	32
10.7 Replacement of low-pressure gaskets.....	33
10.8 Replacement of pistons.....	34
10.9 Re-assembly of head and sleeves .....	35
10.10 Replacement of shaft oil retainers .....	37
10.11 List of tools required for repairs .....	38
<b>MANUFACTURER'S DECLARATION .....</b>	<b>39</b>

- a) This manual conforms to the state-of-the-art applicable at the time the product was marketed and cannot be considered inadequate solely because it was updated on the basis of new experience. **IDROMECCANICA BERTOLINI S.p.A.** is entitled to update the products and relative manuals without being obliged to update previous products and manuals, except in cases where this is required for exclusively safety reasons.
- b) The **“Bertolini Technical Service”** is at your disposal for any requirement as may arise when the product is used or serviced, or when relative accessories must be chosen.
- c) No part of this manual may be reproduced without the written permission of **IDROMECCANICA BERTOLINI S.p.A.**

## 1-GENERAL SAFETY REGULATIONS

-  The high energy produced by the high-pressure jet is a source of serious danger.
-  The pump must only be used by specifically trained personnel.
-  The high-pressure pipes must be type-approved for the permissible maximum pressure of the installation and equipped with unions mechanically crimped by the manufacturer. The maximum temperature and overpressure must be stamped on them as well as the name of the manufacturer and date of manufacture.
-  Always check the conditions of the installation before beginning work.
-  More specifically, check the conditions of the high-pressure pipes and unions. Make sure that the trigger of the gun functions smoothly, without jerking, and that it immediately returns to its original position when released.
-  Never use a defective high-pressure pipe and do not attempt to repair it. Replace it immediately with an original spare.
-  Keep children and animals well away from the system when it is operating.
-  The system must be installed on a stable, sound, secure base.
-  Wear protective goggles when using the system.
-  Always hold the spray gun with both hands when it is operating.
-  Do not point the jet towards people, animals or fragile objects in general.
-  Do not spray onto electrical equipment, electric power sockets or in their immediate vicinity.
-  Keep all parts of the body well away from the pressurized jet.
-  Only use a fan spray to clean delicate surfaces and keep the nozzle at least 75 mm away.
-  If the system is operated by an internal combustion engine, make sure that the installation area is adequately ventilated. EXHAUST GAS FUMES CAN BE LETHAL!!!
-  All moving parts, especially the transmission components, must be adequately protected against accidental contact.
-  Do not use the machine for cleaning surfaces containing asbestos.
-  Strictly comply with the laws in force governing the disposal of substances that detach from the surfaces through the action of pressurized jets.

***Idromeccanica Bertolini declines all civil or criminal liability for damage or accidents to persons or things deriving from failure to comply with even only one of the aforementioned safety regulations.***

## 2-DESCRIPTION OF THE PRODUCT

Bertolini high pressure piston pumps are suitable for pumping fresh, clean water, with a minimum temperature of 5°C and a maximum of 60°C.

If liquids other than those indicated above are used, it is necessary to contact the "Bertolini Technical Department".

The pump must be used in compliance with the specifications given on the data plate (fig. 1). Removal of the data plate will void all forms of warranty.

As soon as the pump arrives, make sure that the data plate is similar to the one depicted below.

**The data plate gives the following information:**

1. Pump model
2. Serial number
3. Maximum permissible pressure in bars
4. Maximum permissible pressure in P.S.I.
5. Flow rate in l/min
6. Flow rate in US GPM
7. Rotational speed
8. Power consumption of pump in kW

**⚠ Never exceed the maximum pressure and rpm rate indicated on the data plate.**

bar - PSI	l/min - GPM	RPM	kW
1000-14500	15.2 - 4.0	700	29.8
	18.2 - 4.8	850	35.8
	21.2 - 5.6	1000	41.7

**OIL SAE 75W 90**

**⚠ If the data plate becomes worn or illegible during use of the pump, contact the dealer or an authorized assistance center and have it replaced.**

## 3-TECHNICAL FEATURES

		PUMP CHARACTERISTICS							CHX SERIES		
		MAX motor rpm	FLOW RATE at max pressure		MAX PRESSURE		POWER trans. to shaft at MAX pressure and flow rate		Shaft	PISTONS	
MODEL	CODE		rpm	l/min	GPM	bars	PSI	kW		HP	No.
CHX 13-1000	74.1035.97.3	750	17	4.4	1000	14500	32.9	44.1	1" 3/8 DIN 9611	3	14
CHX 24-1000	74.1036.97.3	750	18.8	5	1000	14500	36.9	49.5		3	15
CHX 21-1000	74.1030.97.3	1000	21.2	5.6	1000	14500	41.7	55.9	Ø 40	3	14
CHX 25-1000	74.1037.97.3	1000	24.4	6.4	1000	14500	47.9	64.2		3	15

### 3.1 Identification of components

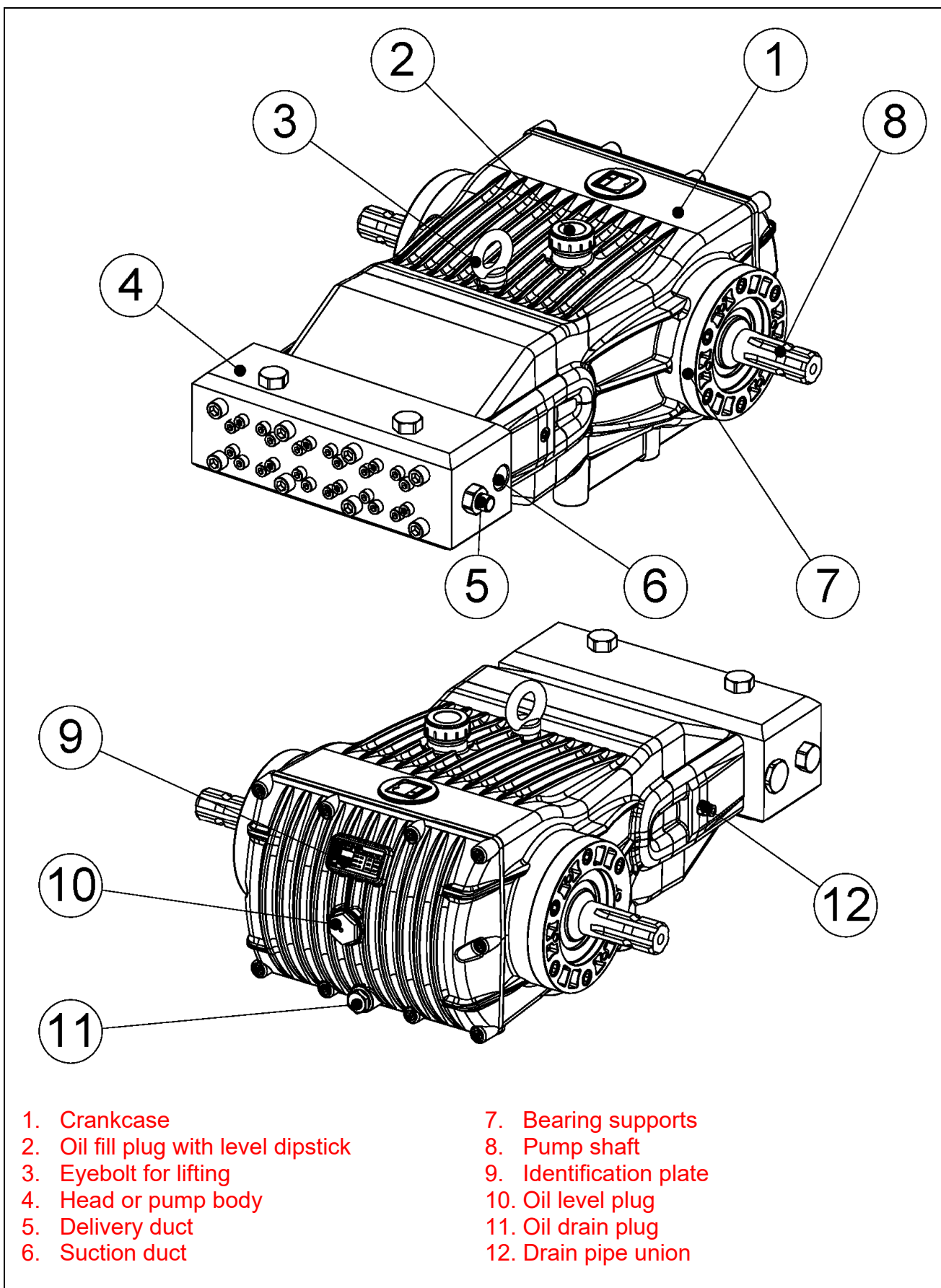



## 3.2 Instructions for use

- The pump is exclusively designed for:
  - Use with clean water at temperatures between +4°C and +60°C for non-food purposes.
  - Use of detergents in a watery solution.
- The pump cannot be used with:
  - Watery solutions with viscosity and density values exceeding those of water;
  - Chemical solutions of which compatibility with the materials with which the pump is made is not known;
  - Sea water or water with a high concentration of salt;
  - Fuels and lubricants of all kinds and types;
  - Inflammable liquids or liquefied gases;
  - Food-grade liquids;
  - Solvents and diluents of all kinds and types;
  - Paints of all kinds and types;
  - Liquids at temperatures lower than 4°C or higher than 60°C;
  - Liquids containing granules or solids in suspension.
- The pump must not be used for washing: persons, animals, electrical equipment, delicate objects, the actual pump itself or the system in which it is installed.
- The pump must not be used in places where there are particular conditions, such as corrosive or explosive atmospheres, for example.

**All other use is considered improper.**

**The manufacturer shall not be liable for any damage deriving from improper or incorrect use.**

The pump is supplied with oil type SAE 80W - 90. Use a product with the same characteristics if the oil must be changed or topped up.

## 4-INSTALLATION

Bertolini pumps comply with the safety regulations laid down by standard EN 809 and are designed to be coupled, either directly or via a transmission, to an electric, heat or hydraulic motor.



**The machine or system of which the pump is a part must be constructed in accordance with good engineering practice and with the safety regulations in force in the country in which the machine itself is installed.**

**In Europe, this condition is testified by the CE mark and by the declaration of conformity provided by the machine manufacturer.**



Correct installation is a key factor for the smooth running and long life of the pump. 90% of faults and failures are caused by:

- Incorrect pump-motor coupling.
- Incorrect sizing or poor construction of the feeding circuit.
- Poor quality or incorrect calibration of the maximum pressure or bypass valve.

***Idromeccanica Bertolini* declines all liability regarding failure to comply with the following instructions:**

### 4.1 Pump connection to the frame

The system must be installed on a stable, sound, safe base using the six M14 holes at the base of the crankcase.

### 4.3 Pump-motor coupling

**The manufacturer of the system is responsible for choosing and correctly sizing the drive system, also in relation to the risks to people that the chosen system could cause.**



When connecting to electric motors, comply with the instructions given by standard EN60204.1 against risks of an electrical nature.



To prevent their accidental contact with parts of the body, all moving components that transmit motion from the motor to the pump must be adequately protected, as specified in Machinery Directive 2006/42/EC or according to the regulations in force in the country of use.



If the pump shaft has a double prime mover, the unused one must be suitably protected.



If the transmission or shaft protection is damaged or breaks, stop the system immediately and have it checked by a specialized technician.



Do not touch the shaft protection with the hands or feet during use.

- The pump must operate with the axis of the pistons horizontal in order to ensure that all its moving parts are properly lubricated.
- The pump-motor assembly must be securely fastened to a sufficiently large and strong base.
- All the electrical connections must be made by specialized technicians.
- If the motor is directly coupled, make sure that:
  - The drive shaft is perfectly aligned with the pump shaft.
  - The steady pin is of the prescribed length.
  - The connection coupling is the right size.
- If a reduction gear is used, the recommendations given in the previous point also apply with reference to the coupling between drive shaft – output shaft and layshaft - pump shaft.

### 4.3 V-belt transmission

The pump can be controlled by a system of V-belts or timing belts.

Minimum diameter of driven pulley (on pump shaft):  $\geq 250$  mm.

The radial load on the shaft must not exceed 7500 N.

Consult technical manuals or contact the “*Bertolini Technical Service*” if the sizing is different.

- If pulleys are used for coupling, check that:
  - There is no play between shafts and pulleys.
  - The pulleys are parallel and aligned.
  - The belts are pre-tensioned to the correct value. Excessively tight belts will lead to early wear on the bearings.

### 4.4 Hydraulic connections

- The body of CHX series pumps features two 3/4” GAS inlets and four 1/2” GAS outlets, 2 of which can be used for a pressure gauge and safety valve. There is also a union for connecting the drainage outlet of the cooling circuit to a zero-pressure vessel or to the suction circuit, so as to re-circulate the fluid.

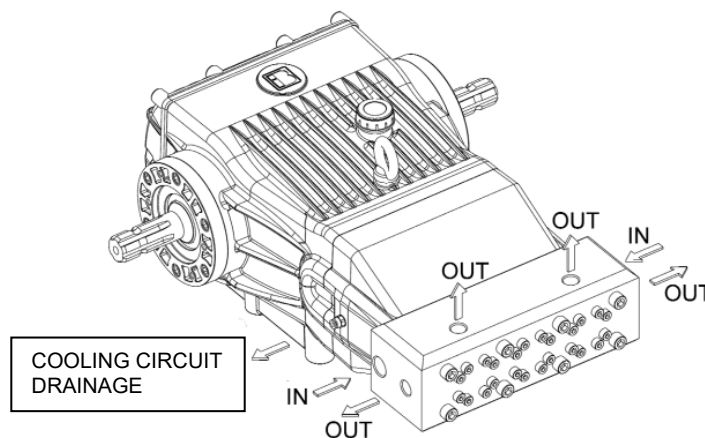

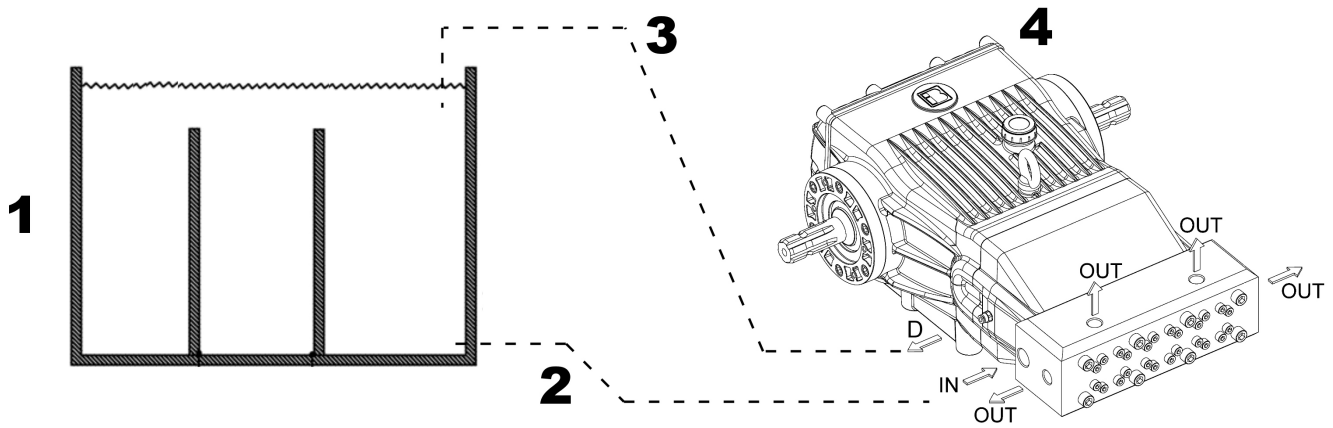

- 1-Feeder tank
- 2-Suction line
- 3-Drainage line
- 4-Pump
- IN-Suction union (there are two unions, but one can be used if preferred - on the side that facilitates the installation work)
- OUT-Delivery union (there are 4 unions available, to be used as required)
- D-Drainage union (there are two unions, but one can be used if preferred - on the side that facilitates the installation work)

NOTE: If there is no tank in the application, connect the drainage line to the pump suction side

## 4.5 Filtering and feeding circuit

- The feeding circuit must be sized so as to avoid the risk of cavitation. Instructions on how to size the feeding circuit are given in the next section 5.2 D. Always check to make sure that the pressure does not drop below -0.2 bars for 750 rpm pumps or +2 bars for 1000 rpm pumps by positioning a pressure switch/pressure gauge behind the pump suction union (shown in point 7 of the assembly layouts).
- The pump feeding pressure must never exceed 5 bars.
- The feeding line must be equipped with a **filter**, with 200 mesh filtration grade for non-supercharged pumps. Filters with higher filtering grades can be used for supercharged pumps. Whatever the case, the filters installed must not lower the suction pressure indicated above. Consult section 5.2 B for further details. The presence of the filter leads to a concentrated pressure drop which reduces the height from which the pump can draw fluid. A filter with an adequate nominal flow rate must be chosen to prevent this height reduction from being excessive. It is advisable to use a filter with a nominal flow rate equal to at least 2.5 times the nominal flow rate of the pump.
- The diameter of the filter ducts must not be less than the diameter of the pump feeding union.
- The filter must be installed as near as possible to the pump and in an easily accessed position. It must be inspected regularly, depending on the degree of cleanliness of the water.
- If water is supplied under pressure by a centrifugal pump, make sure that the flow rate supplied is at least 1.5 times that of the pump.
- Comply with the following instructions if the supply comes from a tank
  - The tank capacity must be at least four times the pump flow rate per minute.
  - The pump feeding pipes must be positioned near to the bottom of the tank,

- with a water head of at least 200 mm to prevent siphons from forming.
- The suction area must be protected against turbulence created by the tank feeding pipe and return pipes, using closed diverters on the bottom.
- The tank must be equipped with the safety devices indicated in sections 5.2 E and 5.2 F.
- It is advisable to install a section of pipe right beside the pump using suitable hoses and to insulate the rest of the system from the vibrations produced by the pump-motor assembly.
- Only use crush-resistant reinforced rigid or flexible pipes.
- The feeding lines must be as straight as possible, with curves, bends and sharp changes in section reduced to the minimum.
- Do not use fittings of the oil-pressure type, 90° bends, multiple-way unions, swivel-joints, etc.
- Avoid using foot valves or check valves in general.
- Do not install detergent suction devices along the pump feeding circuit.
- Before it is connected to the pump, make sure that the feeding line is perfectly clean inside.

## 4.6 High pressure circuit

- ⚠ The minimum performance values (pressure and flow rate) of all the high-pressure circuit components must be at least 30% higher than those the pump can reach.
- ⚠ The high-pressure circuit must be equipped with a **pressure regulating valve** and a **safety valve**, as indicated in section 5.2 A
- ⚠ The name of the manufacturer and the pressure, flow rate and maximum operating temperature values must be stamped on the safety valve and regulating valve.
- ⚠ If the safety valve continues to trip, immediately stop the pump and have the system checked by a specialized technician.
  - Do not connect the safety valve outlet or regulating valve outlet to the feeding line.
  - If the regulating valve is the automatic type, it is advisable to install an adequately sized pressure accumulator immediately after the pump.
- ⚠ The accumulator must be sized to suit the performance of the pump and must comply with the instructions supplied by the manufacturer.
 

The following data must be stamped on the body of the device: manufacturer's trademark, permissible max pressure, test pressure, preload pressure, capacity and date of manufacture. When tests are to be performed, the serial No. and test code required in the country where the machine is installed must also be indicated.

  - It is advisable to make the first section of pipe using hoses able to insulate the rest of the system from the vibrations produced by the pump-motor assembly.
- ⚠ **The hose pipes** must be stamped with the name of the manufacturer, date of manufacture, permissible maximum temperature and pressure values, and their unions must be mechanically crimped directly by the manufacturer.
  - Use glycerin-filled pressure gauges able to withstand pulsating pressure.
  - The high-pressure circuit must be equipped with a pressure shut-off device for pump start-up.

As already mentioned regarding the feeding circuit, the high pressure circuit is also subject to loss of pressure depending on its conformation. So much so, it is normal for the pressure at the application to be lower than that measured at the pump head.

## 4.7 General installation layouts

### TYPICAL CHX PUMP INSTALLATION

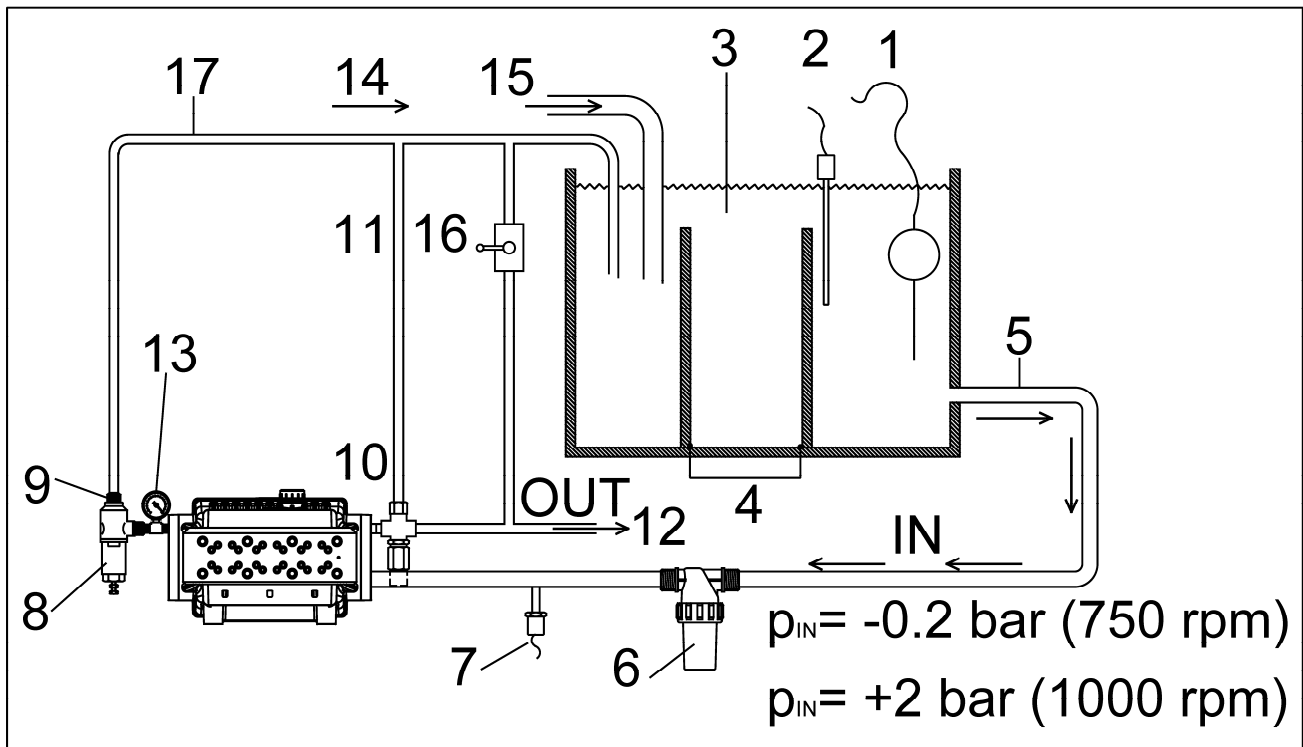

- 1) Level switch;
- 2) Thermostat;
- 3) Minimum tank capacity= pump flow rate x 4;
- 4) Closed diverters on bottom;
- 5) Feeding line clear passage  $\text{Ø}37$
- 6) Filter on suction side (200 mesh  $\rightarrow$  750 rpm;  $\geq 200$  mesh  $\rightarrow$  1000 rpm);
- 7) Pressure switch / Pressure gauge to monitor supply;
- 8) Safety valve;
- 9) Safety valve bypass;
- 10) Regulating or pressure relief valve;
- 11) Regulating valve bypass;
- 12) Delivery;
- 13) Pressure gauge;
- 14) Bypass line;
- 15) Tank feed;
- 16)  $\frac{3}{4}$ " pressure shut-off cock for pump start-up;
- 17) Minimum passage  $\text{Ø}22$ .

## 4.8 Errors to avoid

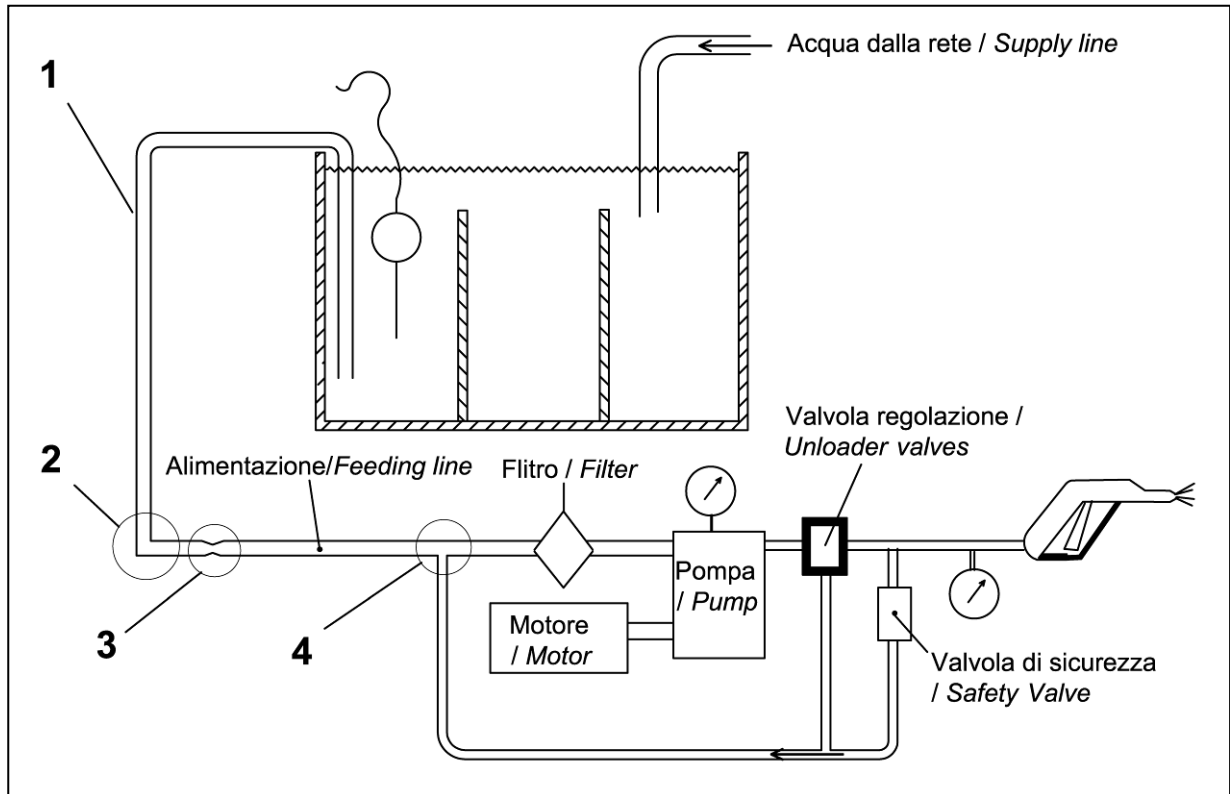

- 1) Avoid, otherwise a “siphon” effect could be created;
- 2) Avoid 90° bends;
- 3) Avoid reductions in diameter;
- 4) Never connect the bypass line to the feeding line return.

## 5- SAFETY AND FAULT PREVENTION DEVICES

### 5.1 Safety devices

The system in which the pump is installed must always be equipped with the safety devices described below:

- **Safety valve:** this is an appropriately calibrated relief valve, which relieves the excess pressure if a fault occurs in the high-pressure circuit.
- **Pump shaft protection:** Prevents the operator from accidentally coming into contact with moving parts of the shaft and transmission.
- **Pressure regulating valve:** This valve allows the operating pressure to be regulated and excess fluid to flow back into the tank, thus preventing the pressure from rising dangerously.

### 5.2 Fault prevention

#### 5.2 A) Protection against overpressure

This is a displacement pump, so the same amount of water always comes out at each turn of the shaft. Since the liquids are practically incompressible, if an impurity accidentally clogs the nozzle and prevents the water from flowing out, the pistons would actually push against a solid element. Without a protection valve, the pump would be immediately destroyed in these conditions.

##### **Safety valve.**

A good quality safety valve of the right size overcomes these problems.

If, however, during normal use (with a spray gun and washing system for instance), the water is frequently shut off, it is re-circulated by the relief valve at calibration pressure, causing overheating and consequently damaging the pump.

##### **Automatic regulating and bypass valve.**

An automatic valve reduces this problem since the water is re-circulated at a very low pressure in this type of valve and takes much longer to heat.

#### 5.2 B) Protection against abrasive particles

No water is free from impurities and abrasive particles, even drinking water.

Not only do abrasive particles rapidly damage the seals, but they also cause the inlet and delivery valves, the regulating valves and nozzles to wear out very quickly.

**A filter**, of an adequate size, installed immediately upstream of the pump guarantees a long service life to the entire system

**However, remember that the filter must always be efficient and clean and must be inspected even daily.**

#### 5.2 C) Protection against cavitation and sizing of the suction circuit (NPSHr)

Cavitation is caused by the formation of gaseous bubbles in the feeding circuit and leads to wear on the gaskets and erosion of the metal parts of the pump.

The most evident sign of cavitation is a continuous or intermittent hammering sound from the pump. In addition, the performance, pressure and flow rate often reduce or become discontinuous.

All liquids tend to form vapor, and this tendency is especially evident when the temperature rises or when the suction head drops.

During their return stroke, the pistons generate a vacuum which draws water into the pumping chambers. The greater the resistance the water opposes along the route from the



tank to the pump, the higher will be the value of the vacuum created by the pump, a condition which consequently increases the risk of cavitation.

This resistance is due to two crucial factors.

- Concentrated pressure losses: due to the presence, along the line, of bends, curves, unions, cocks, filters, etc., all obstructions to the regular flow of water which oppose a certain resistance, mainly depending on their size and geometric shape.
- Distributed pressure losses: due to the friction created between the moving water and sides of the pipes. The value of these losses is proportional to the length of the pipe. It increases as the roughness inside the pipe increases and, water flow rate being equal, increases as the internal diameter of the pipe decreases.

Other pressure losses are due to: the temperature of the water and altitude of the place where the pump is used with respect to sea level.

When a system is designed, one must therefore remember that the pressure of the water at the pump inlet will always be lower than that at the beginning of the feeding line.

**To prevent cavitation, the minimum difference in level Hz between the level of the water and the pump must comply with the following relation:**

$$H_z > (NPSH_r + C) + H_1 + H_2 - (H_{atm} - H_3) \quad (\text{m \& \text{ } }^\circ\text{C}) \text{ or } (\text{ft \& \text{ } }^\circ\text{F})$$

Where:

**NPSH<sub>r</sub>**: net positive suction head required at the suction port of the pump. The value to assign to CHX pumps is 6.5 m (21.3 ft)

**H<sub>z</sub>** = minimum difference in level (positive or negative) between the pump and the water in the tank;

**C** = 0.5m (1.65 ft);

**H<sub>1</sub>** = pressure losses in the pipes and unions (see tabs. 1 and 2);







**H<sub>2</sub>** = pressure losses depending on the temperature of the water (see tab. 3)

**H<sub>atm</sub>** = barometric pressure at sea level = 10.33m (33.9 ft)

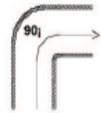
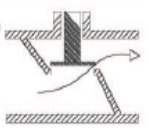
**H<sub>3</sub>** = pressure losses due to height above sea level (see tab. 4)

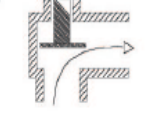
### DATA FOR THE CALCULATIONS

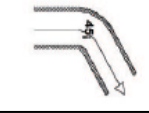
**Table 1** Equivalent length of unions, for various dimensions, in m (ft) of steel pipe

		1/2"	3/4"	1"	1"1/4	1"1/2			1/2"	3/4"	1"	1"1/4	1"1/2
	ft	0,41	0,54	0,69	0,90	1,05		ft	1,67	2,21	2,81	3,70	4,31
	m	0,12	0,16	0,21	0,27	0,32		m	0,51	0,67	0,86	1,13	1,31
	ft	18,50	24,50	31,20	41,00	48,00		ft	3,71	4,90	6,25	8,22	9,59
	m	5,64	7,47	9,51	12,50	14,63		m	1,13	1,49	1,91	2,51	2,92
	ft	9,30	12,30	15,60	20,50	24,00		ft	0,93	1,23	1,56	2,06	2,40
	m	2,83	3,75	4,75	6,25	7,32		m	0,28	0,37	0,48	0,63	0,73
	ft	0,78	1,03	1,31	1,73	2,15		ft	3,33	4,41	5,62	7,40	3,08
	m	0,24	0,31	0,40	0,53	0,66		m	1,01	1,34	1,71	2,26	0,94

**Table 2** Losses per 10 m (10 ft) of steel pipe for various dimensions and flow rates

GPM	L/min	1/2"	3/4"	1"	1"1/4	1"1/2
1	3,785	0,2				
2	7,6	0,50				
2,1	8	0,60				
3	11,4	1,10	0,3			
3,2	12	1,40	0,35			
3,5	13,2	1,50	0,4			
4	(15)	1,70	0,45			
4,8	18	2,50				0,6
5,5	(21)	3,4	0,7	0,1		
6,3	24	4,3	1,1	0,2		
8	(30)	6,4	1,5	0,4		
9,2	35	8,5	1,9	0,6		
10,6	40	11,1	2,6	0,8	0,1	
13,2	50		3,7	1,2	0,3	
16	(60)		5,5	1,5	0,4	0,1
18,5	(70)		7,5	1,8	0,5	0,2
21	(80)		9,5	2,2	0,6	0,3
26,5	(100)			4,5	1,2	0,6
31,5	(120)			8,5	2,2	1,1
37	(140)			12,8	3,5	1,5
40	(150)				3,8	1,8

**Table 3** Loss of suction with temperature of the water

°C	°F	m	ft	°C	°F	m	ft
10	50	0,08	0,26	55	131	1,80	5,91
15	59	0,12	0,39	60	140	2,00	6,56
20	68	0,20	0,66	65	149	2,60	8,53
							10,8
25	77	0,28	0,92	70	158	3,30	3
							15,0
30	86	0,40	1,31	75	167	4,60	9
							16,4
35	95	0,52	1,71	80	176	5,00	0
							19,6
40	104	0,70	2,30	85	185	6,00	9
							24,2
45	113	0,92	3,02	90	194	7,40	8
							30,5
50	122	1,20	3,94	95	203	9,30	1

**Table 4** Suction loss depending on height above sea level

Altezza Elevation Haut Altura		Perdita Loss Perte Pérdida		Altezza Elevation Haut Altura		Perdita Loss Perte Pérdida	
m	ft	m	ft	m	ft	m	ft
500	1640	0,55	1,80	2000	6562	2,2	7,22
1000	3281	1,1	3,61	2500	8202	2,75	9,02
1500	4921	1,65	5,41	3000	9843	3,3	10,83

## CALCULATION EXAMPLE

Example of a calculation for a CHX 21-1000 pump installed at 500 m above sea level

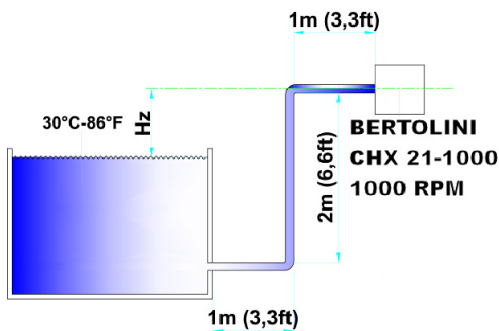

Length of pipes (drawing)	1+1+2=	4.00 m
	3.3+6.6+3.3=	13.20 ft
Equivalent length of unions (tab.2)	2X1.31=	2.62 m
	2X4.31=	8.62 ft
Total length		6.62 m
		21.82 ft
H1 (tab.3)	0.6X6.62/10=	0.4 m
	0.6X21.8/10=	1.31 ft
H2 (tab.4)	30°C	0.40 m
	86°F	1.31 ft
H3 (tab.5)	500 m	0.55 m
	1640 ft	1.80 ft
NPHSr	RPM 1000	6.50 m
	RPM 1000	21.30 ft
<b>H<sub>z</sub></b> >(6.5+0.5)+0.4+0.4-(10.33-0.55)=		<b>-1.98 m</b>
<b>H<sub>z</sub></b> >(21.3+1.65)+1.31+1.31-(33.9-1.8)=		<b>-6.53 ft</b>

Size of pipes and unions G1" 1/2

The calculation shows that the pump can suck from a height of 1.98 m (6.53 ft). If the H<sub>z</sub> value is positive, the pump should be supplied under the head of water.

### 5.2 D) Protection against overheating

Besides reducing the life of the gaskets, operation with very hot water can cause cavitation and must be avoided.

#### Reduced rotational speed of the motor.

If the pump is connected to an electric motor controlled by a speed converter, it is worthwhile installing a device that reduces the rotational speed of the motor and, consequently, the pump flow rate, when the bypass valve is operating. This ensures that the water does not heat so much.

**A thermostat** installed in the tank that trips when the water becomes too hot or, when possible, stops the pump motor, is another recommended safety system.

### 5.2 E) Protection against insufficient or no water supply

The pump must never operate dry, since this would lead to abnormal wear on the gaskets and cause overheating, which could break the pistons or irreparably damage the pump itself.

**A level switch** that signals when there is insufficient water in the tank or, when possible, that stops the pump motor, is recommended for the purpose of preventing the pump from running dry.

**A pressure switch**, which trips with an alarm signal or, if possible, which stops the motor when the supply pressure drops below the value liable to cause cavitation, should be installed upstream of the pump suction duct.



If the level switch, thermostat or pressure switch trip and stop the motor, the switch used must be the manual starting type to prevent the motor from restarting on its own.

### 5.2 F) Energy saving / correct use of the pump

It is fairly frequent for the flow rate of the pump to be oversized with respect to the effective requirements.

To correctly size the system, the water re-circulated through the regulating valve must not exceed 10-15% of the pump flow rate.

Otherwise, besides causing an unnecessary waste of energy, the water in the supply tank will overheat and contribute towards increasing the risk of cavitation. In addition, all the components in the circuit, especially the regulating valves, will be subjected to continuous and excessive stress.

In short, the flow rate of the pump must always be adapted to the effective requirements of the system by reducing the rotational speed of the pump itself.

## 6- FAQ

Question: By how much must the pump speed rate be reduced to obtain a lower flow rate?

Answer: Required speed rate = Required flow rate x  $\frac{\text{Permissible max. rpm}}{\text{Permissible max flow rate}}$

Question: What motor pulley diameter is able to obtain this speed rate?

Answer: Outer diam. of motor pulley = Outer diam. of pump pulley x  $\frac{\text{Pump speed rate}}{\text{Motor rpm}}$

Question: What if the motor pulley cannot be replaced?

Answer: Outer diam. of pump pulley = Outer diam. of motor pulley x  $\frac{\text{Motor rpm}}{\text{Pump speed rate}}$

Question: If a motor has a lower rate than the max. rate indicated on the data plate, which is the maximum flow rate that can be obtained?

Answer: Maximum flow rate obtainable =  
Motor rpm x  $\frac{\text{Maximum flow rate indicated on data plate}}{\text{Max. rpm on data plate}}$

Question: Which is the approximate power required to obtain the permissible max. performance?

Answer: Power required (kW) =  $\frac{\text{Max flow rate (l/min)} \times \text{Max pressure (bars)}}{524}$

Our technical service is at your disposal for any further information required.

## 7- PUTTING INTO SERVICE

### Preliminary inspections

- Make sure that the feeding line is connected and hermetically sealed.
- Make sure that the filter is clean.
- Check that all the on-off valves (if any) along the feeding line are open and that water flows freely to the pump. **The pump must never run dry.**
- Check that all the delivery pipes are connected to a user.
- The coupling tolerances between pump shaft and transmission (misalignment of half-couplings, cardan shaft angle, shaft-pulley play, belt tensioning, etc.) must be within the limits established by the transmission manufacturer.
- Install the oil plug with dipsticks in place of the non-vented oil plug (red). This operation may have already been performed by the manufacturer of the machine in which the pump is installed.
- Check that when the pump is at a standstill, the oil level reaches the center-line of the oil telltale. The oil level can also be checked by unscrewing the vented plug: the correct level is between the two notches on the dipstick. Remember that the oil level must always be checked when the pump is at a standstill and completely cooled.
- Before starting the pump, carefully read the instructions in this manual and in the manual of the machine in which the pump is installed.
- Make sure that the moving parts of the pump are adequately protected and that they cannot be accessed by unauthorized persons.
- Make sure that ice does not form inside the pump if it is used at very low temperatures.
- Perform the preliminary operations required by the manufacturer of the machine in which the pump is installed.

### WARNING

- **The pump cannot be put into service unless the machine in which it is installed conforms to the safety requirements established by the European Directives. This fact is guaranteed by the CE marking applied and by the Declaration of Conformity of the manufacturer of the machine in which the pump is installed.**
- Do not use the pump if:
  - it has been subjected to shocks and impact;
  - there are evident oil leaks;
  - there are evident water leaks;In these cases, have the pump checked by a **Specialized Technician**.
- Supplementary maintenance inspections have to be performed by a **Specialized Technician**.

## 7.1 Start-up

- Start the pump without a load after having set the pressure regulating valve to “zero” or by opening the relief devices if any.
- Make sure that the speed rate does not exceed the value on the data plate.
- Before bringing the pressure to the required value, wait until all the air in the circuit has been released and that water flows out in a constant, continuous jet.

 In winter and when there is a risk of freezing temperatures, it is essential to make sure that there is no ice in the entire circuit (feeding and delivery) before starting the pump.

**Do not start the pump before having allowed the circuit to completely thaw.**

## 7.2 Use



Warning! If used improperly, the high-pressure jet can cause damage to persons, animals and things.

Apart from regulating the pressure, **no other operations are required when the system is operating**. For example, the pressure must be reduced to zero and the pump stopped before tightening a plug or union, checking a high-pressure pipe or other.

- The jet of water must always be directed towards the work area even during preliminary tests and inspections.
- Do not start the pump before having directed the jet towards the work area.
- The area covered by the jet must be cordoned off and cleared of all objects which could be damaged or blown away if hit by the jet.
- Always pay attention to the direction taken by the debris removed by the jet of water. Use panels or baffles to protect items which could be accidentally hit by the debris.
- Excessively high pressures could damage the objects which need to be cleaned. It is advisable to perform preliminary tests (operating pressure, distance of the nozzle from the object, etc.).

*Idromeccanica Bertolini S.p.A.* declines all civil or criminal liability for damage to persons or things caused by improper use of the pump and the other parts of the system in which the pump is installed.

## 7.3 Leaking water from the gaskets

- Small amounts of water (a few drops per minute) that spill from the outlet zone in the lower part of the crankcase are perfectly normal as to correct pump operation.

## 7.4 How to stop the pump

- Only stop the pump after having reduced the pressure to zero by means of the regulating valve or other relief devices.
- If chemicals are used, it is essential to thoroughly wash the pump by allowing it to run for a few minutes with clean water. After this, empty the pump by disconnecting the suction part and allowing it to operate for about 20 seconds.
- In winter, when the pump is exposed to cold weather or if it is to remain idle for a long period of time, it is essential to empty all residues of water from the circuit or mix antifreeze liquid with clean water in the correct proportions.

In no case hoses must have fluid on pressure when stopping the pump.  
Carry out the cleaning and maintenance operations recommended by the Producer of the machine incorporating the pump.



Therefore make sure that:

- you have stopped the pump and then closed the water supply.
- you have set the delivery pressure at **zero** bar from the spray gun.
- you have disconnected all connected hoses.

Store the pump in environments with temperatures above 5°C.



**WARNING: if ice is present, do not start the pump for any reason until the circuit is completely defrosted, to avoid very serious damage to the pump.**



## 8- TROUBLESHOOTING

<b>FAULTS</b>	<b>CAUSES</b>	<b>REMEDIES</b>
<b>When started, the pump fails to dispense water and produces no noise</b>	No water is being supplied  Valves blocked  The delivery line is closed and prevents the air in the head from escaping	Check the circuit and level of water in tank.  Check and replace if necessary.  Discharge the delivery line until water is dispensed regularly
<b>The pump is noisy and knocks irregularly</b>	Air drawn in  Insufficient water supply  Valves jammed or worn High pressure gaskets worn Defective regulating valve  Faulty transmission  Speed rate higher than value on data plate	Check suction circuit. Check for air in the circuit  Make sure that feeding circuit has been properly sized. Make sure that filter is clean  Check and replace if necessary.  Check alignments, clearances, settings.  Adjust the speed rate correctly
<b>Vibrations or knocking in the pipes</b>	Air drawn in  Defective regulating valve  The outlet line of the regulating valve is undersized or throttled.  Valves jammed	Check suction circuit. Check for air infiltration  Check and/or replace if necessary  Check sizing and eliminate throttles  Check and/or replace if necessary
<b>The pump functions correctly but fails to provide the indicated performance</b>	Insufficient water supply  Defective or badly adjusted regulating valve Nozzle of the wrong size or worn Worn piston gasket Worn valves  Speed rate lower than value on data plate	Make sure that feeding circuit has been properly sized. Make sure that filter is clean Check and/or replace if necessary  Adjust the speed rate
<b>The pump is noisy and overheats</b>	High water temperature  Operating pressure higher than value on data plate Speed rate higher than value on data plate Belts too taut  Oil not at correct level, or dirty or spent  Bearings damaged	Lower the water temperature  Adjust to correct value  Check, top up or change if necessary  Replace
<b>Water leaking from under pump</b>	Worn piston gaskets Worn O-Ring on piston	Check and/or replace Check and/or replace
<b>Oil leaks</b>	Piston oil retainer damaged	Check and/or replace
<b>Pressure gauge reading fluctuates irregularly at high pressure with spray gun open</b>	Valve contains impurities  Worn pump piston gaskets Worn pump valves	Clean valve and lubricate components with grease  Check and/or replace Check and/or replace

**WARNING!:** the nozzle is a component which is subject to wear and must therefore be replaced if it is no longer possible to reach the required pressure. As it wears and the size of the outlet hole consequently becomes larger, the effective flow rate increases and leads to a drop in pressure

## 9- WARRANTY

The liability of Idromeccanica Bertolini during the warranty period (12 months from the date of delivery) is limited to replacement of parts recognized as being defective by Idromeccanica Bertolini itself.

The warranty is only valid when the defect can be ascertained by the Assistance Service and when it is not ascribable to improper use or negligent maintenance of the pump.

Parts subject to normal wear-and-tear (parts made of rubber, plastic, gaskets) and labor costs are not covered by the warranty.

### **The warranty is valid:**

- When the pump has been used in full compliance with its technical specifications.

### **The warranty becomes void:**

- In the case of damage caused by malfunctioning of the regulating valve;
- If the pump operates without sufficient water on the suction side;
- If the pump operates without oil;
- If the pump is damaged through exposure to freezing temperatures;
- If the pump functions for an excessively long time in the bypass mode.

### **USE OF NON-ORIGINAL SPARE PARTS WILL RESULT IN NON-RECOGNITION OF THE WARRANTY**

Products may only be sent for the purposes of inspection if authorized by Idromeccanica Bertolini in writing and only carriage paid.

## 10- ROUTINE MAINTENANCE

### 10.1 Maintenance of drive mechanism and lubrication

- Check the oil level at least once a week using the dipstick and top up if necessary.
- Change the oil using SAE 80W - 90 oil once the pump has functioned for 50-100 hours after first start-up. After this, change the oil after every 1000 hours service or once a year to ensure a correct lubricating action.
- **If the pump is used in very damp climates or environment, it is normal for the water in the air to condense and mix with the pump oil, which will turn a typically whitish color. If this happens, the oil must be checked more frequently and immediately changed in the presence of water.**
- If water is found in the oil, immediately check to find out where it enters and change the relative seals. Thoroughly wash the crankcase and drive mechanism before changing the oil.

**WARNING!** Allowing the pump to operate with emulsified oil (containing water, condensation, etc.) reduces the lubricating action of the fluid on the moving parts. This leads to overheating and possible damage.



Protect the environment from the liquids in the pump. Collect the residues and dispose of them regularly. No residue must be allowed to enter the distribution network or soil.

**WARNING!** The operations described below must be performed with the proper equipment, supplied on request, and always by specialized personnel. Operations performed without the proper equipment can cause serious damage to the pump.

## 10.2 Hydraulic circuit maintenance

Replacement of gaskets or valves are the only operations required.

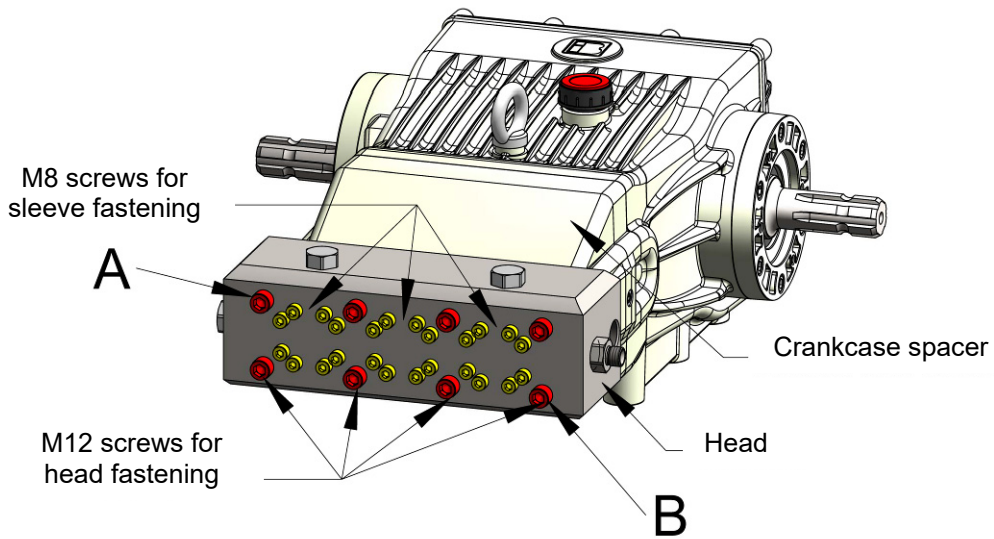

## 10.3 Disassembly of head and sleeves

- Loosen the M8 screws that fasten the sleeves, without removing them.
- Unscrew the two M12 bolts that fasten the head (A and B) and replace them with screw-plugs (code 77.3943).

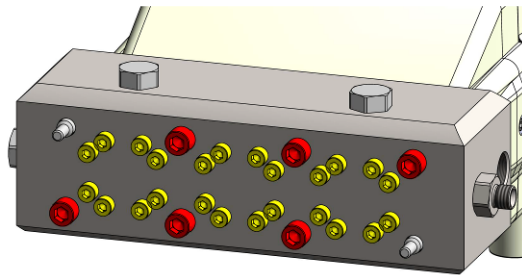

- Remove the remaining M12 bolts that fasten the head.
- Split the head, with the sleeves still attached, from the crankcase spacer.

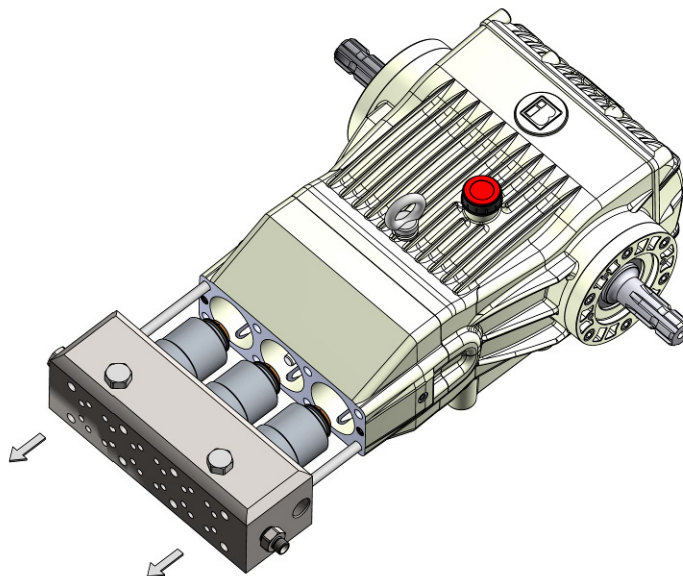

## 10.4 Replacement of the suction and delivery valves

- Remove the M8 screws that fasten the sleeve and remove this latter, taking care to prevent the internal components from dropping.

### 10.4 A) Suction valves

- Remove the plates, the springs and the spring guides from the sleeves (keep the components of the three pumping elements separate, if the used parts are going to be re-assembled).
- Inspect the contact surfaces between plate and valve housing. Replace the components if they are excessively worn.

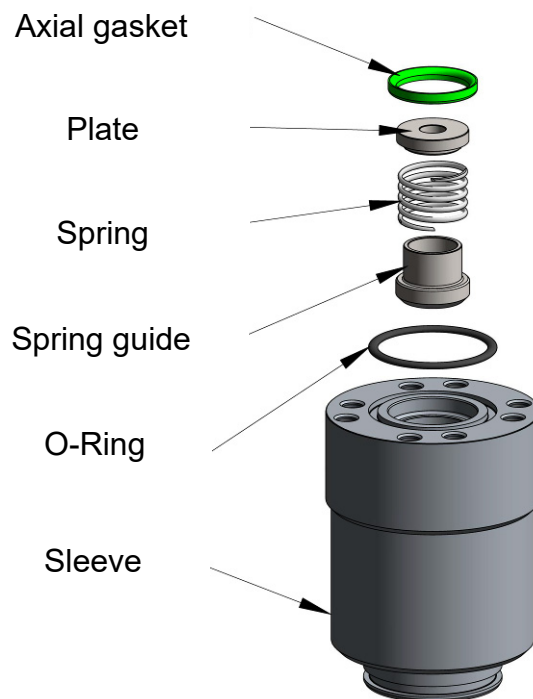
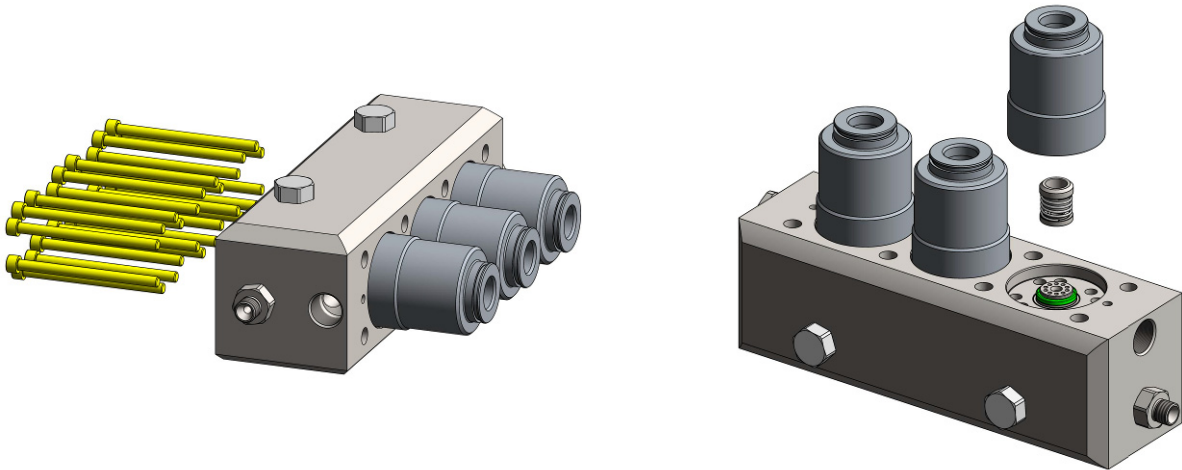

## 10.4 B) Delivery valves

- Remove the valve housings from the head. Certain models have a thread in the central hole of the valve housing. If this is the case, screw in an M8 bolt to facilitate the removal operations. In models without this thread, insert a plug and release the valve housings by applying lateral movements;

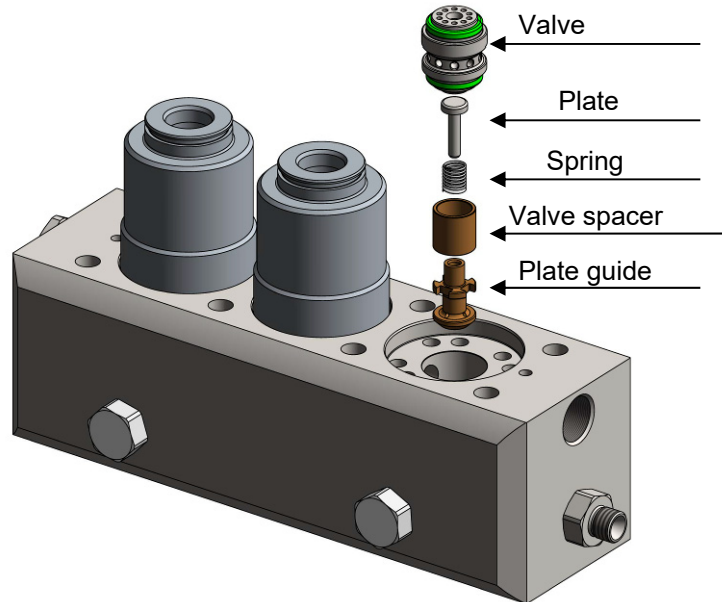

- Remove the plates, springs, valve spacers and valve guides from the head (keep the components of the three pumping elements separate, if the used parts are going to be re-assembled).
  - Inspect the contact surfaces between plate and valve housings. Replace the components if they are excessively worn.
  - Assess the clearance between the plate stem and plate guide. Replace the components if there is too much play.

## 10.5 Replacement of high-pressure gaskets

- Remove the front glands from the sleeves.
- Remove the high-pressure gaskets from the sleeves.
- Position the thimble code 77.3941 on a sleeve and grease the tapering inner part.
- Place a new front gasket in the thimble with the sealing lip pointing downwards.
- Using the plug code 77.3942, insert the front gasket into the sleeve as far as the plug will go. Make sure that you keep the plug aligned with the thimble.
- Replace the O-Rings of the outer slots of the sleeves.
- Grease the glands on the inside and outside, then fit them into the sleeves.

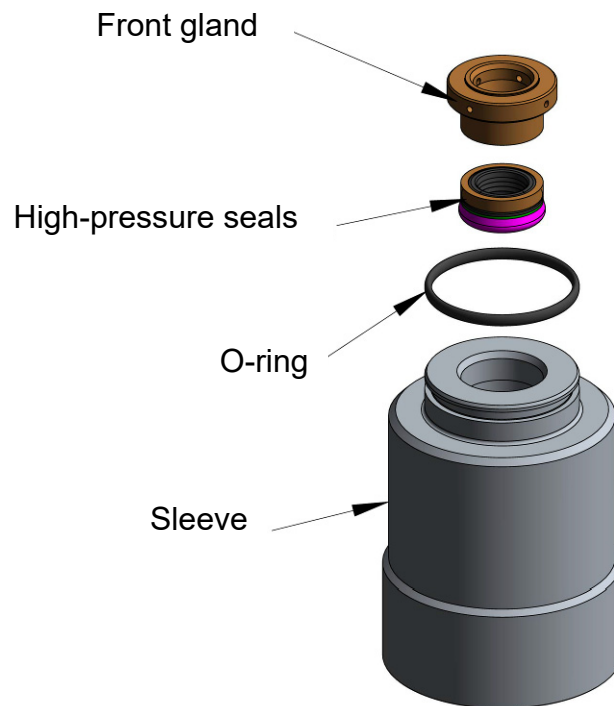

## 10.6 Complete re-assembly of the suction-delivery valves

- Fit the valve components back into the sleeves in the following order: spring guide, spring, plate
- Remove the axial gaskets (they may have remained in position or inside the head or on the valve housing during the disassembly operations).
- Position the new axial gaskets in their housings in the head and sleeves with the aid of plug code 77.3946.
- Replace the O-Ring
- Fit the valve components back into the head in the following order: plate guide, valve spacer, spring, plate.
- Remove the axial gaskets (rings made of plastic material which may have remained in position or inside the head or on the valve housing during the disassembly operations).
- Position the new axial gaskets in their housings in the head and sleeves with the aid of plug code 77.3946.
- Fit the sleeves back on the head, with the delivery valves in their correct position, and partially tighten the M8 screw. There must be about 1 mm of play between sleeves and head.



## 10.7 Replacement of low-pressure gaskets

- Separate the crankcase spacer from the crankcase.
  - Remove the rear glands from the crankcase spacer.
  - Remove the rear pack (rear gasket and anti-extrusion ring).
  - Replace the O-Rings of the outer slots of the rear glands.
  - Lubricate the O-Rings on the rear glands.
  - Fit the rear glands back into the crankcase spacer.

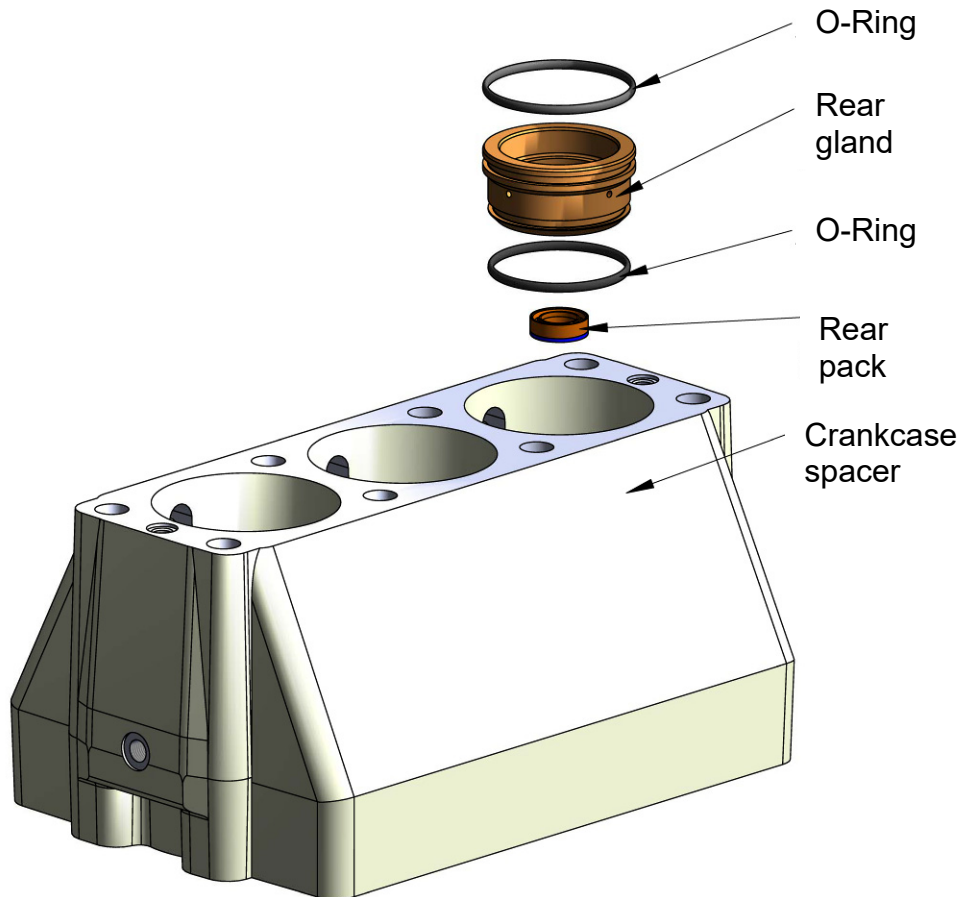

- Position the crankcase spacer on the screw-plug in the crankcase and allow it to slide fully against the crankcase
- Grease the pistons and position the rear pack (anti-extrusion rings and rear gaskets) onto the pistons
- Allow the rear packs to slide onto the pistons with the aid of plug code

Plug	Pump model
77.3944	CHX 13-1000 CHX 24-1000
77.3958	CHX 21-1000 CHX 25-1000

- NOTE. the operations highlighted by this symbol must not be performed if only the gaskets are replaced, with the rear glands kept in position on the crankcase spacer.

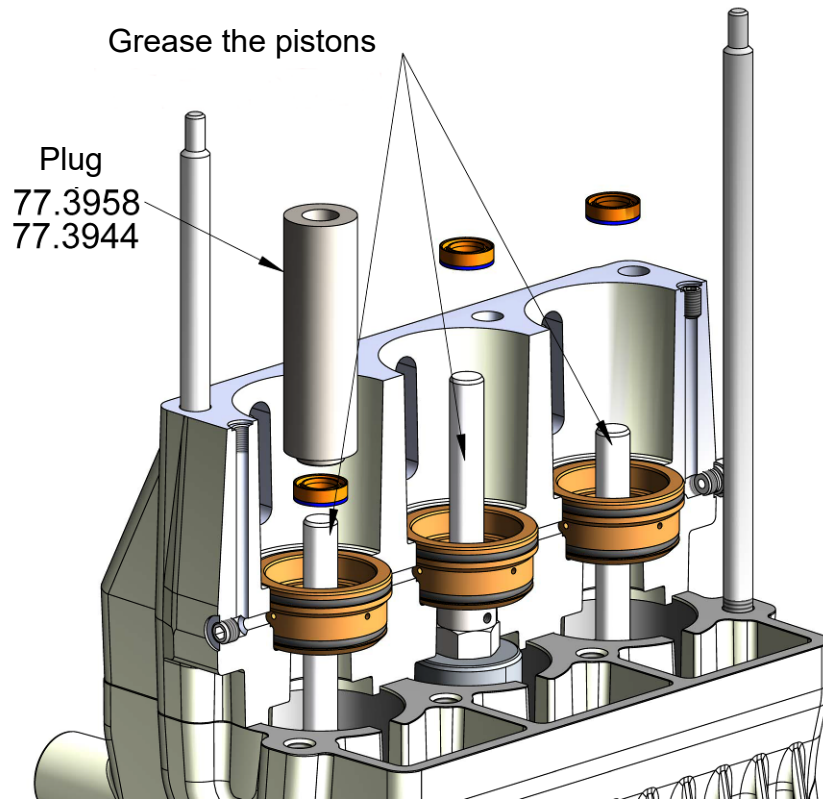

## 10.8 Replacement of pistons

- Separate the crankcase spacer from the crankcase.
- Unscrew the pistons.

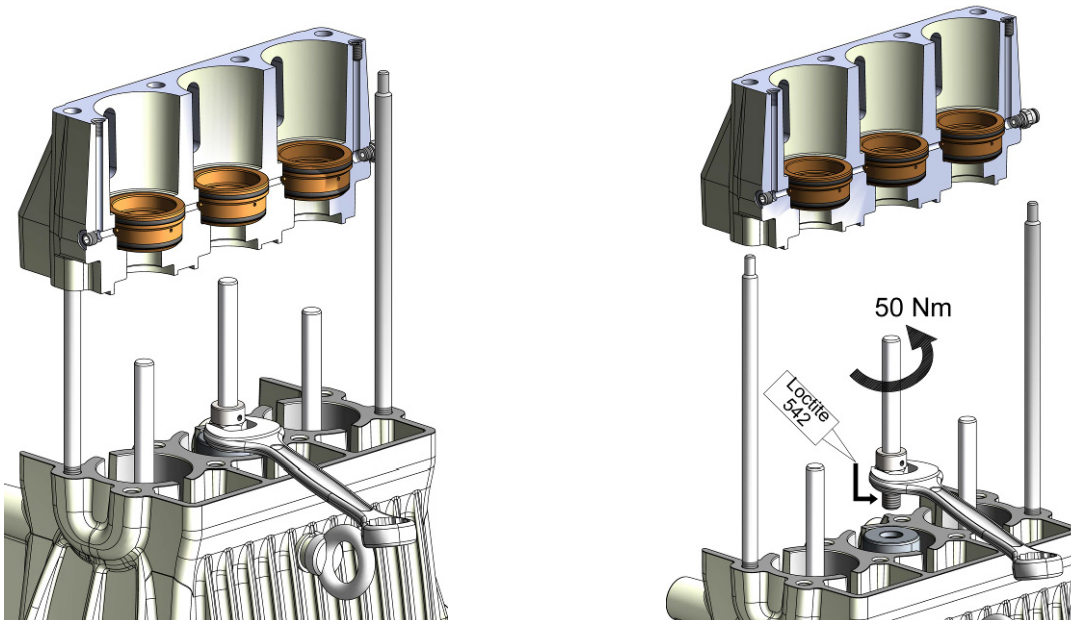

- Thoroughly clean the remaining Loctite from the threaded holes of the piston guideways.
- Apply Loctite 542 to the threads of the pistons and screw them into the piston guideways using 50 Nm torque.
- Repeat these operations for the other two pistons.
- Fit the crankcase spacer back in place until it centers and rests on the pump crankcase

- Grease the pistons, insert the anti-extrusion rings and rear gaskets.
- Using plug code 77.3944, position the rear packs in the housings of the rear glands and seat them as far as they will go with the plug.

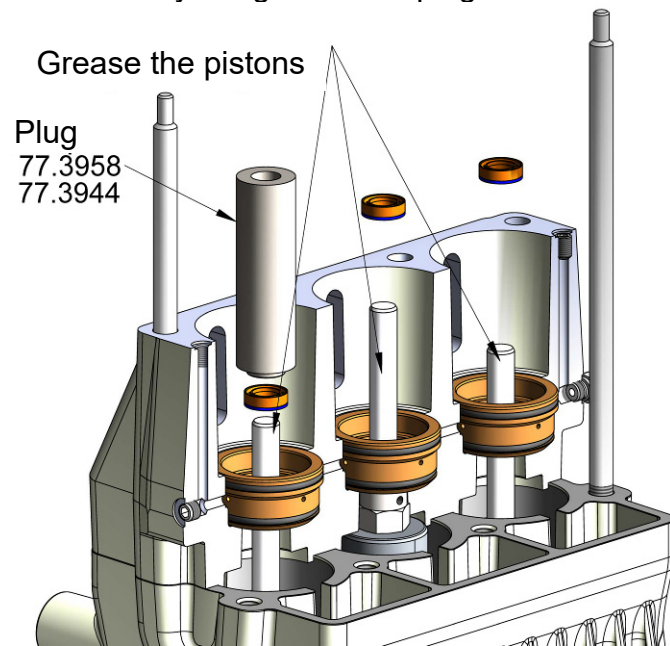

## 10.9 Re-assembly of head and sleeves

- Turn the shaft so as to expose the three pistons and grease.
- Grease the O-Ring on the outer diameter of each sleeve.
- Make sure that the rear packs are positioned in their housings, using plug code 77.3944-77.3958.
- Fit the O-Rings in their housings on the crankcase spacer. Apply a little grease to make sure they remain in position.

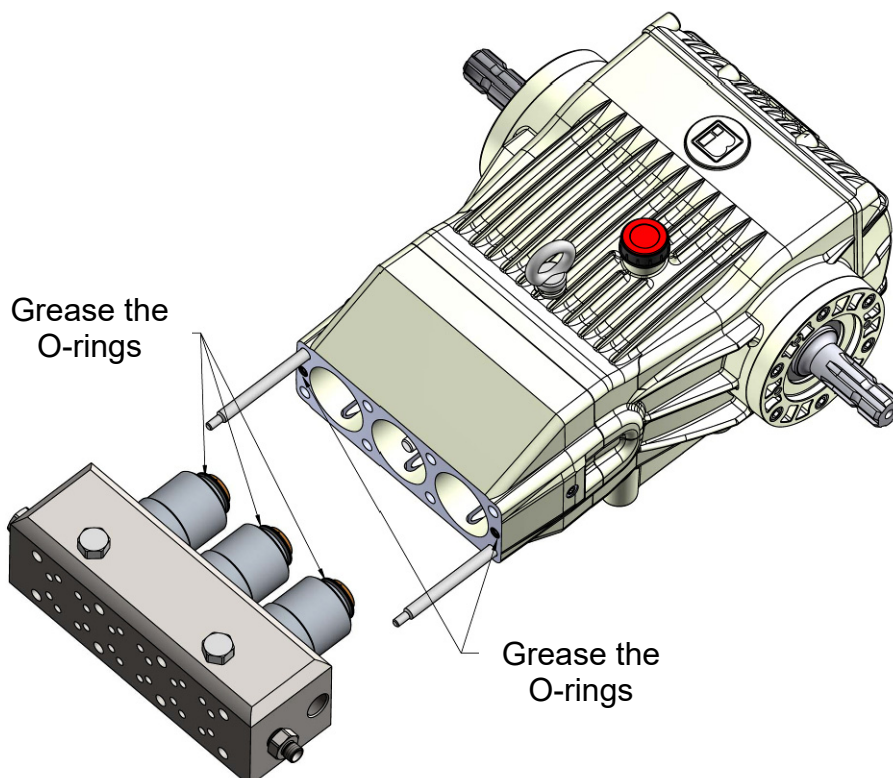

- Position the pump crankcase assembly on the two screw-plugs 77.3943. Make sure that the O-Rings on the crankcase spacer do not drop, then, with the aid of a plastic mallet, push the pump crankcase assembly fully against the crankcase spacer.
  - Insert six M12x260 screws into the pump crankcase and tighten the screws of pos. 1-2-3-4 in a crosswise manner, in that order, using at least 20-30 Nm torque, so as to keep the pump crankcase and pistons square to each other.

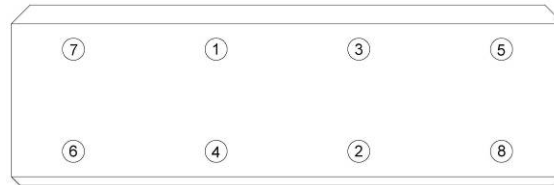

- Remove the two screw-plugs and insert the remaining two M12 screws in their place.
- Tighten all the M12 screws that fasten the head in the following sequence:
  - 1) Tighten all screws to 60 Nm
  - 2) Tighten all screws to 100 Nm
  - 3) Tighten all screws to 100 Nm
- Tighten the M8 screws that fasten the sleeve. Comply with the following sequence for each pumping element:
  - 1) Tighten all screws to 20 Nm
  - 2) Tighten all screws to 35 Nm
  - 3) Tighten all screws to 35 Nm

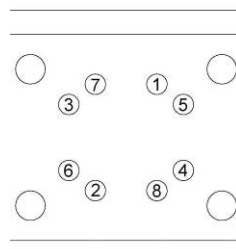

## 10.10 Replacement of shaft oil retainers

### Disassembly:

#### STEP 1:

With the aid of a mallet, insert a flat-tip screwdriver into the metal support of the retaining ring (fig. 4).

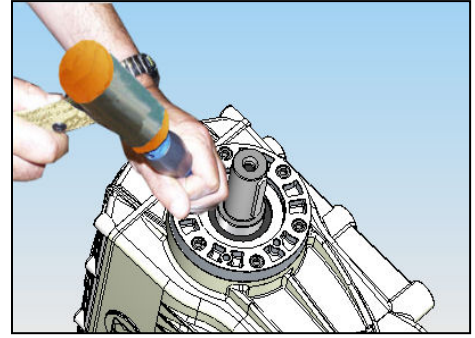

Fig. 4

#### STEP 2:

Remove the retaining ring by levering as indicated in figure 5.

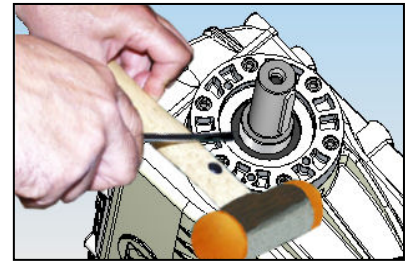

Fig. 5

### Re-assembly:

Insert the new retaining ring into the relative plug (fig. 6) and fit it into its housing with the aid of a mallet (fig. 7).



Fig. 6

**Warning:** do not attempt to re-assemble the retaining ring without the relative plug (see list of tools required for repairs) since the grooves or seat of the key on the shaft would certainly damage the sealing edge.

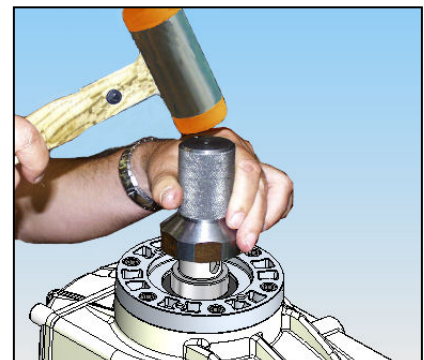

Fig. 7

## 10.11 List of tools required for repairs

The tools required for the repairs are available in a kit supplied on request.  
The individual tools can also be ordered individually:

Complete kit	Tool code	Description	Q.ty
77.9912.97.A Piston D.14	77.3943	M12x270 assembly plug	2
	77.3946	Plug for seating axial gasket of valves	1
	77.3944	Plug for seating rear gaskets	1
	77.3941	Thimble for seating front gaskets	1
	77.3942	Plug for seating front gaskets	1

Complete kit	Tool code	Description	Q.ty
77.9912.97.B Piston D.15	77.3943	M12x270 assembly plug	2
	77.3946	Plug for seating axial gasket of valves	1
	77.3958	Plug for seating rear gaskets	1
	77.3956	Thimble for seating front gaskets	1
	77.3957	Plug for seating front gaskets	1

# MANUFACTURER'S DECLARATION

## *Manufacturer's declaration*

Machinery Directive 2006/42/EC (Annex II B)

Idromeccanica Bertolini S.p.A.

declares, under its sole responsibility, that the pumps of series

CHX

with serial number

(to be filled in by the purchaser according to the identification label)

- has been manufactured to be incorporated into a machine or to be assembled with other equipment to form a machine as provided for by Directive 2006/42/EC;

- conformity with all points of the provisions established by the aforementioned Directive is the responsibility of the manufacturer of the machine into which the pump is incorporated.

Idromeccanica Bertolini S.p.A. therefore declares that the aforementioned product must not be put into service until the machine into which it will be incorporated or of which it will become a component has been declared as compliant with the provisions established by Directive 2006/42/EC, i.e. until the product to which this declaration refers forms a single entity with the final machine.

Reggio Emilia 01.07.2018

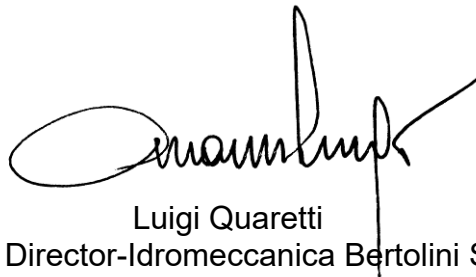

Luigi Quaretti  
(Managing Director-Idromeccanica Bertolini S.p.A.)

